

TOSHIBA

SERVICE MANUAL

COLOUR TELEVISION

21N21D

SERVICING NOTICES ON CHECKING

1. KEEP THE NOTICES

As for the places which need special attentions, they are indicated with the labels or seals on the cabinet, chassis and parts. Make sure to keep the indications and notices in the operation manual.

2. AVOID AN ELECTRIC SHOCK

There is a high voltage part inside. Avoid an electric shock while the electric current is flowing.

3. USE THE DESIGNATED PARTS

The parts in this equipment have the specific characters of incombustibility and withstand voltage for safety. Therefore, the part which is replaced should be used the part which has the same character.

Especially as to the important parts for safety which is indicated in the circuit diagram or the table of parts as a  mark, the designated parts must be used.

4. PUT PARTS AND WIRES IN THE ORIGINAL POSITION AFTER ASSEMBLING OR WIRING

There are parts which use the insulation material such as a tube or tape for safety, or which are assembled in the condition that these do not contact with the printed board. The inside wiring is designed not to get closer to the pyrogenic parts and high voltage parts. Therefore, put these parts in the original positions.

5. TAKE CARE TO DEAL WITH THE CATHODE-RAY TUBE

In the condition that an explosion-proof cathode-ray tube is set in this equipment, safety is secured against implosion. However, when removing it or serving from backward, it is dangerous to give a shock. Take enough care to deal with it.

6. AVOID AN X-RAY

Safety is secured against an X-ray by considering about the cathode-ray tube and the high voltage peripheral circuit, etc.

Therefore, when repairing the high voltage peripheral circuit, use the designated parts and make sure not modify the circuit.

Repairing except indicates causes rising of high voltage, and it emits an X-ray from the cathode-ray tube.

7. PERFORM A SAFETY CHECK AFTER SERVICING

Confirm that the screws, parts and wiring which were removed in order to service are put in the original positions, or whether there are the portions which are deteriorated around the serviced places serviced or not. Check the insulation between the antenna terminal or external metal and the AC cord plug blades. And be sure the safety of that.

(INSULATION CHECK PROCEDURE)

1. Unplug the plug from the AC outlet.
2. Remove the antenna terminal on TV and turn on the TV.
3. Insulation resistance between the cord plug terminals and the eternal exposure metal **[Note 2]** should be more than 1M ohm by using the 500V insulation resistance meter **[Note 1]**.
4. If the insulation resistance is less than 1M ohm, the inspection repair should be required.

[Note 1]

If you have not the 500V insulation resistance meter, use a Tester.

[Note 2]

External exposure metal: Antenna terminal
Earphone jack

HOW TO ORDER PARTS

Please include the following informations when you order parts. (Particularly the VERSION LETTER.)

1. MODEL NUMBER and VERSION LETTER

The MODEL NUMBER can be found on the back of each product and the VERSION LETTER can be found at the end of the SERIAL NUMBER.

2. PART NO. and DESCRIPTION

You can find it in your SERVICE MANUAL.

IMPORTANT

Inferior silicon grease can damage IC's and transistors.

When replacing an IC's or transistors, use only specified silicon grease (YG6260M).

Remove all old silicon before applying new silicon.

CONTENTS

SERVICING NOTICES ON CHECKING	A1-1
HOW TO ORDER PARTS	A1-1
IMPORTANT	A1-1
CONTENTS	A2-1
GENERAL SPECIFICATIONS	A3-1~A3-5
DISASSEMBLY INSTRUCTIONS	
1.REMOVAL OF ANODE CAP	B1-1
2.REMOVAL AND INSTALLATION OF FLAT PACKAGE IC	B2-1, B2-2
SERVICE MODE LIST	C-1
CONFIRMATION OF HOURS USED	C-1
WHEN REPLACING EEPROM(MEMORY) IC	C-2
ELECTRICAL ADJUSTMENTS	D-1~D-5
BLOCK DIAGRAM	E-1, E-2
PRINTED CIRCUIT BOARDS	
MAIN/CRT	F-1~F-4
SCHEMATIC DIAGRAMS	
MICON/TUNER	G-1, G-2
IF/CHROMA	G-3, G-4
21PIN	G-5, G-6
DEFLECTION/CRT	G-7, G-8
POWER	G-9, G-10
SOUND AMP	G-11, G-12
WAVEFORMS	H-1~ H-3
MECHANICAL EXPLODED VIEW	I-1
MECHANICAL REPLACEMENT PARTS LIST	J1-1
ELECTRICAL REPLACEMENT PARTS LIST	J2-1~ J2-4

GENERAL SPECIFICATIONS

G-1	TV System	CRT	CRT Size / Visual Size	21 inch / 544.5mmV	
			CRT Type	NORMAL	
			Deflection	90 degree	
			Magnetic Field BV/BH	+0.45G/0.18G	
			Color System	PAL	
			Speaker	1 Speaker	
				Position	Front
				Size	1.5 x2.5 Inch
				Impedance	4 ohm
			Sound Output	MAX	5.0 W
				10%(Typical)	4.0 W
			DDR SECAM		No
			NTSC3.58(AV)+NTSC4.43		Yes
	PAL60Hz		Yes		
G-2	Tuning System	Broadcasting System		CCIR System B/G	
		Tuner and Receive CH	System	1Tuner	
			Destination	Hyper	
			Tuning System	F-Synth	
			Input Impedance	VHF/UHF 75 ohm	
			CH Coverage	E2 - E4, X - Z+2, S1 - S10, E5 - E12, S11 - S41, E21 - E69	
				B/G	
			Intermediate Frequency	Picture(FP) Sound(FS) FP-FS	38.9 MHz 33.4 MHz 5.5MHz
			Preset CH		100
			Stereo/Dual TV Sound		No
			Tuner Sound Muting		Yes
G-3	Power	Power Source	AC	230V AC 50Hz	
			DC		
		Power Consumption		at AC	
			Stand by (at AC)		60 W at AC 230 V 50 Hz
			Per Year		3 W at AC 230 V 50 Hz
			-- kWh/Year		
	Protector	Power Fuse		Yes	
G-4	Regulation	Safety		CE(EN60065:98)	
		Radiation		CE	
		X-Radiation		-	
G-5	Temperature	Operation		+5oC ~ +40oC	
		Storage		-20oC ~ +60oC	
G-6	Operating Humidity			Less than 80% RH	

GENERAL SPECIFICATIONS

G-7	On Screen Display	Menu	Menu Type	Yes
			Character	Yes
			Picture	Yes
			Contrast	Yes
			Brightness	Yes
			Color	Yes
			Tint (NTSC Only)	Yes
			Sharpness	Yes
			Audio	No
			Bass	No
			Treble	No
			Balance	No
			BBE On/Off	No
			Stable Sound On/Off	No
			CH Tuning	Yes
			Manual	Yes
			Auto	Yes
			CH Allocation	Yes
			Language	Yes
			Clock Set	No
			On Timer Set	Yes
			Off Timer Set	Yes
			Pin Code Registration	No
			Panel Lock	Yes
			Nicam Auto Off	No
			AV Color System	Yes
			Sound System	No
			Auto 4:3 Default	No
			AV2 Output	No
			Output Source	No
			Source	No
			Control Level	Yes
			Volume	Yes
			Brightness	Yes
			Contrast	Yes
			Color	Yes
			Tint (NTSC Only)	Yes
			Sharpness	Yes
			Tuning	Yes
			Bass	No
Treble	No			
Balance	No			
Back Light	No			
Nicam ST	No			
Tone 1/2 (A/B)	No			
Surround On/Off	No			
Pin Code	No			
AV	Yes			
Skip	Yes			
Channel	Yes			
Hotel Lock	No			
Sleep Timer	No			
Wide Mode	No			
Sound Mute	Yes			
G-8	OSD Language		English French Spanish German Italian Greek Turkish Swedish Dutch Portuguese Norwegian Finnish Danish	
G-9	Clock and Timer	Sleep Timer	Max Time	- Min
			Step	___ - Min
		Clock		No
		On Timer	Program(On Timer)	Yes
		Off Timer	Program(Off Timer)	Yes
		Wake Up Timer		No
	Timer Back-up (at Power Off Mode)	more than	-- Min Sec	

GENERAL SPECIFICATIONS

G-10	Remote Control	Unit	RC-EY	
		Glow in Dark Remocon	No	
		Format	NEC	
		Custom Code	40-BF h	
		Power Source	Voltage(D.C) UM size x pcs	3V UM-4 x 2 pcs
		Total Keys		32 Keys
		Keys	Power	Yes
			1	Yes
			2	Yes
			3	Yes
			4	Yes
			5	Yes
			6	Yes
			7	Yes
			8	Yes
			9	Yes
			0	Yes
			Volume Up / +	Yes
			Volume Down / -	Yes
			Previous	Yes
			Select Picture	Yes
			Menu	Yes
			OK(Enter)	Yes
			EXIT	No
			Audio Select	No
			Sleep Timer	No
			Mute	Yes
		TTEXT Keys	TEXT / MIX / TV	Yes
			CH Up / Page Up	Yes
			CH Down / Page Down	Yes
			Red	Yes
			Green	Yes
	Yellow	Yes		
	Cyan	Yes		
	TEXT F/T/B	Yes		
	Reveal	Yes		
	TIMED PAGE(SUB PAGE)	Yes		
	CALL / TEXT INDEX	Yes		
	INPUT SELECT	Yes		
	TEXT HOLD	Yes		
	TIME / TXCL	Yes		
G-11	Features	Auto Degauss	Yes	
		Auto Shut Off	Yes	
		Canal+	No	
		CATV	No	
		Anti-theft(Back Up 30 Min.)	No	
		Memory(Last CH)	Yes	
		Memory(Last Volume)	Yes	
		BBE	No	
		Auto Search	Yes	
		CH Allocation	Yes	
		Just Clock Function	No	
		Game Position	No	
		CH Label	No	
		VM Circuit	No	
		Full OSD	No	
		Unitext	No	
		Fastext	Yes	
		Top Text	Yes	
		Premiere	No	
		Comb Filter	No	
			Lines	
		Auto CH Memory	No	
		Stable Sound	No	
		Auto Set Up	No	
		FBT Leak Test Protect	Yes	
		Previous (Quick View)	Yes	
		Panel Lock	Yes	
		Power ON Memory	Yes	
		Double Focus & Dynamic Focus	No	
Wss Signal Wide Change	No			
Virtual Dolby Surround	No			
Hotel Lock	No			

GENERAL SPECIFICATIONS

G-12	Accessories	Owner's Manual	Language w/Guarantee Card	Germany Italian Dutch Greek Turkish	
				No	
		Remote Control Unit		Yes	
		Rod Antenna	Poles Terminal	Pole type	No
		Loop Antenna	Terminal	-	No
		U/V Mixer			No
		DC Car Cord (Center+)			No
		Guarantee Card			No
		Warning Sheet			No
		Circuit Diagram			No
		Antenna Change Plug			No
		Service Facility List			No
		Important Safeguard		Yes (Owner's Manual In)	
		Dew/AHC Caution Sheet			No
		AC Plug Adapter			No
		Quick Set-up Sheet		Yes	
		Battery		Yes	
			UM size x pcs	UM-4 x 2 pcs	
			OEM Brand		No
		AC Cord			No
AV Cord (2Pin-1Pin)			No		
Registration Card			No		
PTB Sheet			No		
300 ohm to 75 ohm Antenna Adapter			No		
G-13	Interface	Switch	Front	Power (Tact Sw)	No
				System Select	No
				Main Power SW	Yes
				Sub Power	No
				Channel Up	Yes
				Channel Down	Yes
				Volume Up	Yes
				Volume Down	Yes
				Rear	AC/DC
		TV/CATV Selector	No		
		Degauss	No		
		Main Power SW	No		
		Indicator	Power		No
			Stand-by		No
			Stand-by/ON	Yes(Red)	
		Terminals	Front	On Timer	Yes(Green)
				Video Input	RCA
				Audio Input	RCA
			Rear	Other Terminal	Head Phone (Stereo)
				Video Input(Rear1)	No
				Video Input(Rear2)	No
				Audio Input(Rear1)	No
				Audio Input(Rear2)	No
				Video Output	No
				Audio Output	No
				Euro Scart(21Pin)	No
				S-INPUT	
Euro Scart(21Pin)	Yes (x1)				
RGB-INPUT	Yes (x1)				
Component Input	No				
Diversity	No				
Ext Speaker	No				
DC Jack 12V(Center +)	No				
VHF/UHF Antenna Input	D Type				
AC Outlet	No				
G-14	Set Size	Approx. W x D x H (mm)	506.5 x 484 x 464.5		
G-15	Weight	Net (Approx.)	21.0 kg	(--- lbs)	
		Gross (Approx.)	23.8kg	(---lbs)	

GENERAL SPECIFICATIONS

G-16	Carton	Master Carton	No
		Content	---- Sets
		Material	-- /--
		Dimensions W x D x H(mm)	-- x -- x --
		Description of Origin	---
		Gift Box	Yes
		Material	Double/Brown
		Dimensions W x D x H(mm)	580 x 575 x 555
		Design	As per Buyer's
		Description of Origin	Yes
		Drop Test	Natural Dropping At 1 Corner / 3 Edges / 6 Surfaces
Height (cm)	46		
Container Stuffing	320 Sets/40' container		
G-17	Cabinet Material	Cabinet Front	PS 94HB
		Cabinet Rear	PS 94 HB
		Holder	PS 94V0 NC

DISASSEMBLY INSTRUCTIONS

1. REMOVAL OF ANODE CAP

Read the following **NOTED** items before starting work.

- * After turning the power off there might still be a potential voltage that is very dangerous. When removing the Anode Cap, make sure to discharge the Anode Cap's potential voltage.
- * Do not use pliers to loosen or tighten the Anode Cap terminal, this may cause the spring to be damaged.

REMOVAL

1. Follow the steps as follows to discharge the Anode Cap. (Refer to Fig. 1-1.)

Connect one end of an Alligator Clip to the metal part of a flat-blade screwdriver and the other end to ground. While holding the plastic part of the insulated Screwdriver, touch the support of the Anode with the tip of the Screwdriver. A cracking noise will be heard as the voltage is discharged.

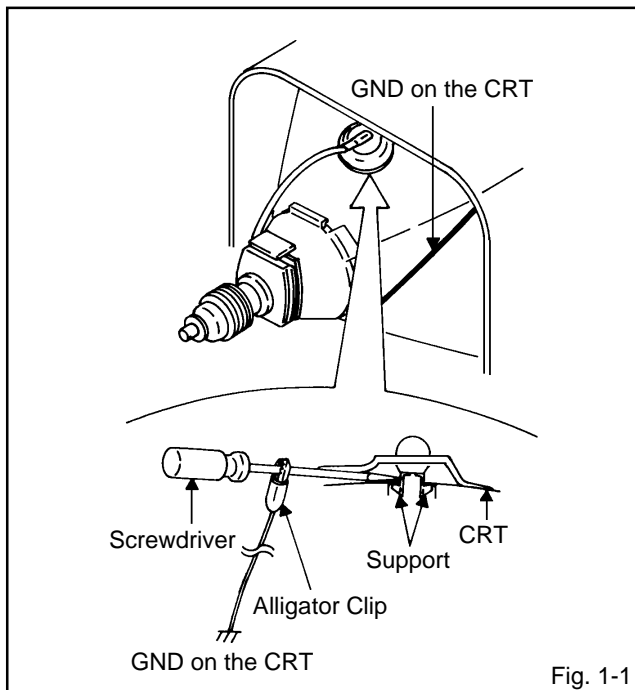

Fig. 1-1

2. Flip up the sides of the Rubber Cap in the direction of the arrow and remove one side of the support. (Refer to Fig. 1-2.)

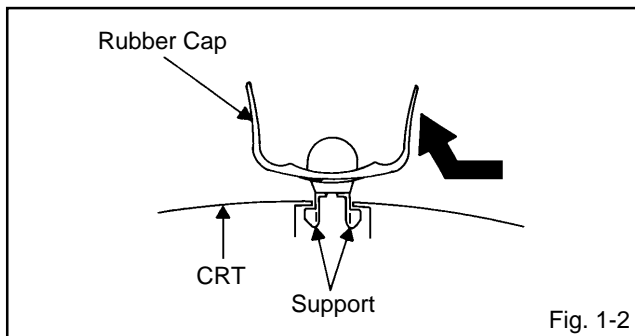

Fig. 1-2

3. After one side is removed, pull in the opposite direction to remove the other.

NOTE

Take care not to damage the Rubber Cap.

INSTALLATION

1. Clean the spot where the cap was located with a small amount of alcohol. (Refer to Fig. 1-3.)

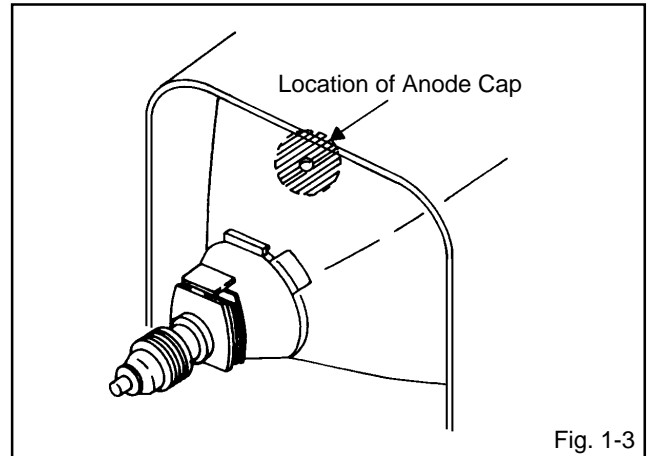

Fig. 1-3

NOTE

Confirm that there is no dirt, dust, etc. at the spot where the cap was located.

2. Arrange the wire of the Anode Cap and make sure the wire is not twisted.
3. Turn over the Rubber Cap. (Refer to Fig. 1-4.)

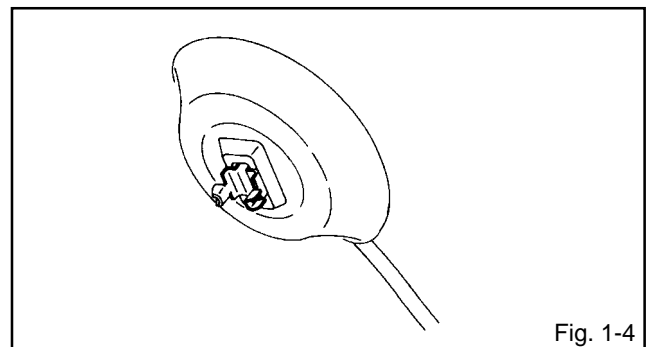

Fig. 1-4

4. Insert one end of the Anode Support into the anode button, then the other as shown in Fig. 1-5.

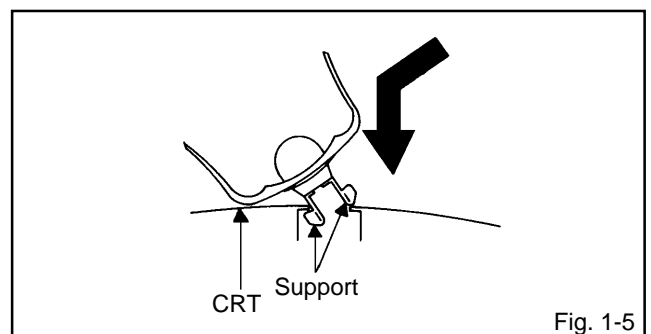

Fig. 1-5

5. Confirm that the Support is securely connected.
6. Put on the Rubber Cap without moving any parts.

DISASSEMBLY INSTRUCTIONS

2. REMOVAL AND INSTALLATION OF FLAT PACKAGE IC

REMOVAL

1. Put the Masking Tape (cotton tape) around the Flat Package IC to protect other parts from any damage. (Refer to Fig. 2-1.)

NOTE

Masking is carried out on all the parts located within 10 mm distance from IC leads.

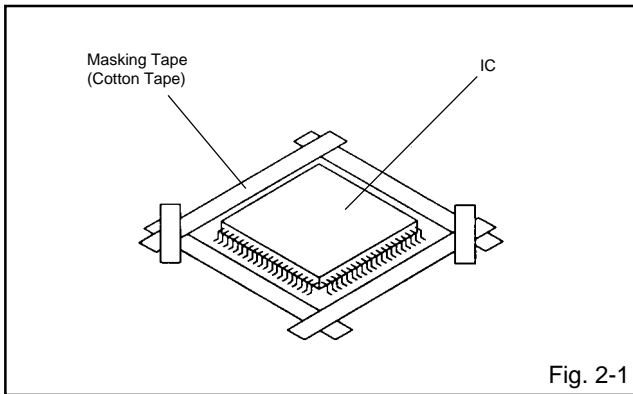

2. Heat the IC leads using a blower type IC desoldering machine. (Refer to Fig. 2-2.)

NOTE

Do not add the rotating and the back and forth directions force on the IC, until IC can move back and forth easily after desoldering the IC leads completely.

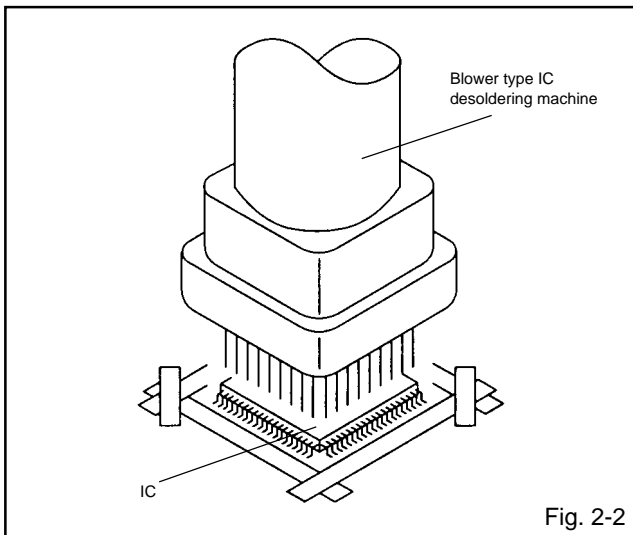

3. When IC starts moving back and forth easily after desoldering completely, pickup the corner of the IC using a tweezers and remove the IC by moving with the IC desoldering machine. (Refer to Fig. 2-3.)

NOTE

Some ICs on the PCB are affixed with glue, so be careful not to break or damage the foil of each IC leads or solder lands under the IC when removing it.

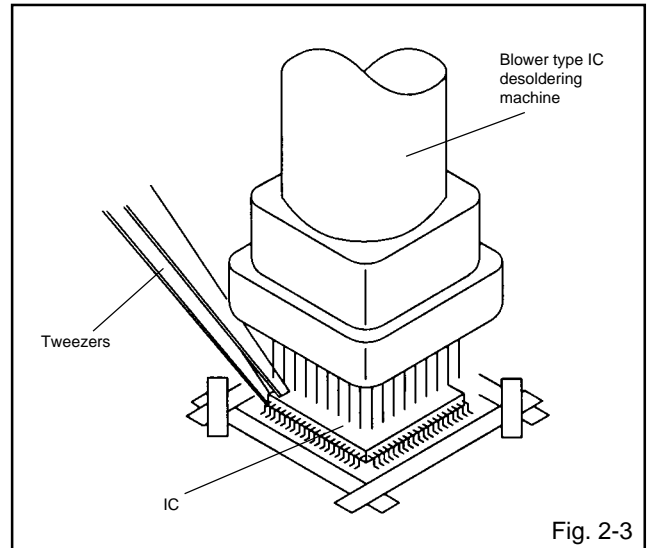

4. Peel off the Masking Tape.

5. Absorb the solder left on the pattern using the Braided Shield Wire. (Refer to Fig. 2-4.)

NOTE

Do not move the Braided Shield Wire in the vertical direction towards the IC pattern.

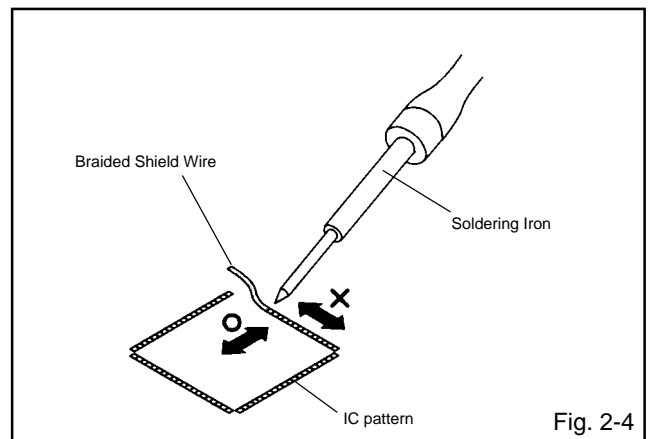

DISASSEMBLY INSTRUCTIONS

INSTALLATION

1. Take care of the polarity of new IC and then install the new IC fitting on the printed circuit pattern. Then solder each lead on the diagonal positions of IC temporarily. (Refer to Fig. 2-5.)

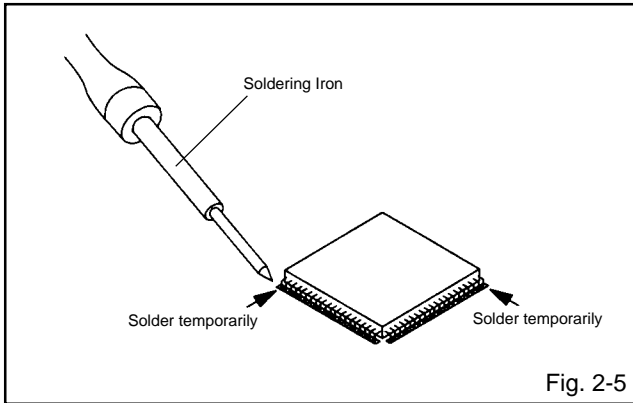

2. Supply the solder from the upper position of IC leads sliding to the lower position of the IC leads. (Refer to Fig. 2-6.)

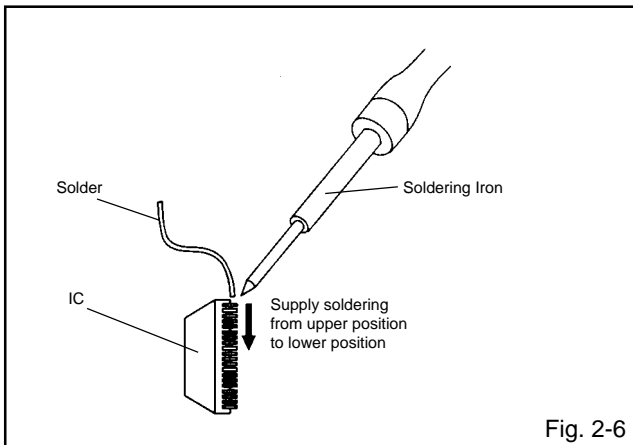

3. Absorb the solder left on the lead using the Braided Shield Wire. (Refer to Fig. 2-7.)

NOTE

Do not absorb the solder to excess.

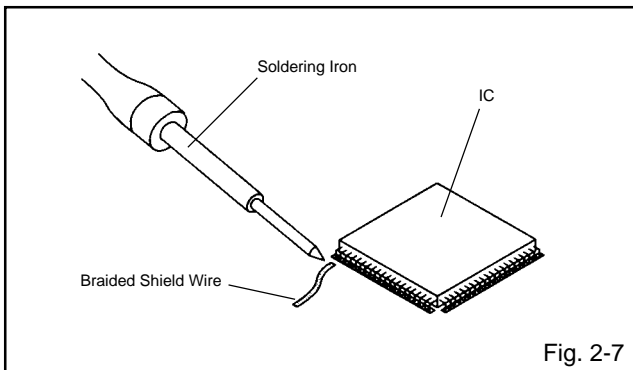

4. When bridge-soldering between terminals and/or the soldering amount are not enough, resolder using a Thin-tip Soldering Iron. (Refer to Fig. 2-8.)

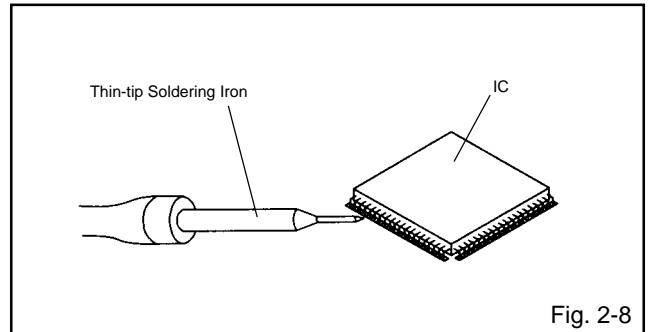

5. Finally, confirm the soldering status on four sides of the IC using a magnifying glass. Confirm that no abnormality is found on the soldering position and installation position of the parts around the IC. If some abnormality is found, correct by resoldering.

NOTE

When the IC leads are bent during soldering and/or repairing, do not repair the bending of leads. If the bending of leads are repaired, the pattern may be damaged. So, be always sure to replace the IC in this case.

SERVICE MODE LIST

This unit provided with the following SERVICE MODES so you can repair, examine and adjust easily.
To enter the Service Mode, press both set key and remote control key for more than 2 seconds.

Set Key	Remocon Key	Operations
VOL. (-) MIN	0	Reset the user setting items (PICTURE, VOLUME, LANGUAGE and NICAM AUTO/OFF) to the initial state for delivery.
VOL. (-) MIN	1	Initialization of the factory. NOTE: Do not use this for the normal servicing. If you set a factory initialization, the memories are reset such as the channel setting, and the POWER ON total hours.
VOL. (-) MIN	6	POWER ON total hours is displayed on the screen. Refer to the "CONFIRMATION OF HOURS USED". Can be checked of the INITIAL DATA of MEMORY IC. Refer to the "WHEN REPLACING EEPROM (MEMORY) IC".
VOL. (-) MIN	8	Writing of EEPROM initial data. NOTE: Do not use this for the normal servicing.
VOL. (-) MIN	9	Display of the Adjustment MENU on the screen. Refer to the "ELECTRICAL ADJUSTMENT" (On-Screen Display Adjustment).

CONFIRMATION OF HOURS USED

POWER ON total hours can be checked on the screen. Total hours are displayed in 16 system of notation.

NOTE: If you set a factory initialization, the total hours is reset to "0".

1. Set the VOLUME to minimum.
2. Press both VOL. DOWN button on the set and Channel button **(6)** on the remote control for more than 2 seconds.
3. After the confirmation of using hours, turn off the power.

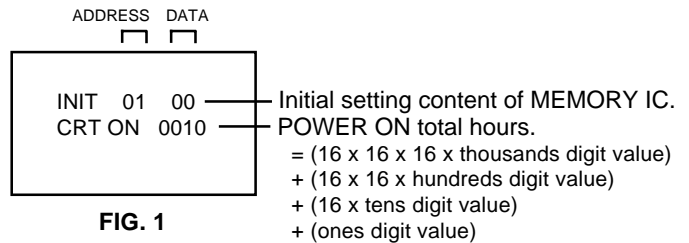

FIG. 1

WHEN REPLACING EEPROM (MEMORY) IC

If a service repair is undertaken where it has been required to change the MEMORY IC, the following steps should be taken to ensure correct data settings while making reference to TABLE 1.

INI	+0	+1	+2	+3	+4	+5	+6	+7	+8	+9	+A	+B	+C	+D	+E	+F
00	---	00	00	00	00	61	80	48	08	43	27	05	83	00	06	73
10	10	00	80	80	80	3C	00	7C	06	9F	32	80	00	44	28	22
20	51	33	32	6D	C0	00	42	20	0F	00	18	00	B0	DD	DC	05
30	00	95	9D	7F	07	00	00	00	00	00	00	00	00	00	00	00
40	7F	6F	5F	4F	3F	39	34	2F	2D	2B	29	27	25	23	21	20
50	1F	1E	1D	1C	1B	1A	19	18	17	16	15	14	13	13	12	12
60	11	11	10	10	0F	0F	0E	0E	0D	0D	0C	0C	0B	0B	0A	0A
70	09	09	08	08	07	07	06	06	06	05	05	05	04	04	04	04
80	22	25	CD	CF	D3	D8	94	97	99	52	54	56	57	59	5B	5D
90	5E	5F	---	---	---	---	---	---	---	---	---	---	---	---	---	---

Table 1

1. Enter DATA SET mode by setting VOLUME to minimum.
2. Press both VOL. DOWN button on the set and Channel button **(6)** on the remote control for more than 2 seconds. ADDRESS and DATA should appear as FIG 1.

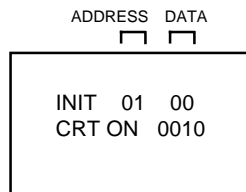

Fig. 1

3. ADDRESS is now selected and should "blink". Using the VOL. +/- button on the remote, step through the ADDRESS until required ADDRESS to be changed is reached.
4. Press OK to select DATA. When DATA is selected, it will "blink".
5. Again, step through the DATA using VOL. +/- button until required DATA value has been selected.
6. Pressing OK will take you back to ADDRESS for further selection if necessary.
7. Repeat steps 3 to 6 until all data has been checked.
8. When satisfied correct DATA has been entered, turn POWER off (return to STANDBY MODE) to finish DATA input.

After the data input, set to the initializing of shipping.

9. Turn POWER on.
10. Press both VOL. DOWN button on the set and Channel button **(1)** on the remote control for more than 2 seconds.
11. After the finishing of the initializing of shipping, the unit will turn off automatically.

The unit will now have the correct DATA for the new MEMORY IC.

ELECTRICAL ADJUSTMENTS

1. ADJUSTMENT PROCEDURE

Read and perform these adjustments when repairing the circuits or replacing electrical parts or PCB assemblies.

CAUTION

- Use an isolation transformer when performing any service on this chassis.
- Before removing the anode cap, discharge electricity because it contains high voltage.
- When removing a PCB or related component, after unfastening or changing a wire, be sure to put the wire back in its original position.
- When you exchange IC and Transistor for a heat sink, apply the silicon grease on the contact section of the heat sink. Before applying new silicon grease, remove all the old silicon grease. (Old grease may cause damages to the IC and Transistor).

Prepare the following measurement tools for electrical adjustments.

1. Oscilloscope
2. Digital Voltmeter
3. Pattern Generator

On-Screen Display Adjustment

1. In the condition of NO indication on the screen. Press the VOL. DOWN button on the set and the Channel button (9) on the remote control for more than 2 seconds to appear the adjustment mode on the screen as shown in Fig. 1-1.

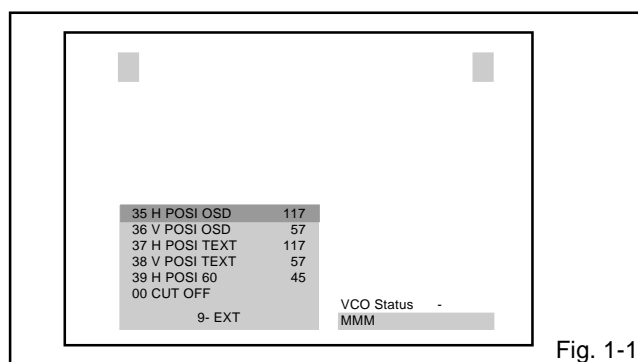

Fig. 1-1

2. Use the Channel button (0-9) or Channel UP/DOWN button on the remote control to select the options shown in Fig. 1-2.
3. Press the MENU button on the remote control to end the adjustments.

NO.	FUNCTION	NO.	FUNCTION
00	CUT OFF	20	TINT
01	RF AGC	21	SHARP
02	AGC GAIN	22	CONTRAST CENT
03	R DRIVE	23	CONTRAST MAX
04	R CUTOFF	24	CONTRAST MIN
05	G DRIVE	25	COLOR CENT
06	G CUTOFF	26	COLOR MAX
07	B DRIVE	27	COLOR MIN
08	H POSI (50)	28	M R CUT OFF
09	V POSI (50)	29	M G CUT OFF
10	V POSI (60)	30	M B CUT OFF
11	V SIZE (50)	31	CVBS OUT
12	V SIZE (60)	32	APR THRESHOLD
13	VCO COARSE	33	BELL FILTER
14	VCO FINE	34	BANDPASS
15	VCO COARSE L1	35	H POSI OSD
16	VCO FINE L1	36	V POSI OSD
17	BRIGHT CENT	37	H POSI TEXT
18	BRIGHT MAX	38	V POSI TEXT
19	BRIGHT MIN	39	H POSI (60)

Fig. 1-2

2. BASIC ADJUSTMENTS

2-1: CONSTANT VOLTAGE

1. Place the set with Aging Test for more than 5 minutes.
2. Connect the digital voltmeter to TP501.
3. Set condition is AV MODE without signal.
4. Adjust the VR501 until the DC voltage is $117 \pm 0.5V$.

2-2: VCO

1. Place the set with Aging Test for more than 10 minutes.
2. Connect the oscillator (38.9MHz) to TP001.
3. Activate the adjustment mode display of Fig. 1-1 and press the channel button (13) on the remote control to select "VCO COARSE".
4. Press the VOL. +/- button on the remote control until the "OK" appear on the screen. If the "OK" is not displayed, select the "+" side on the changed from "+" to "-".
5. Press the Page UP button once to set to "VCO FINE" mode.
6. Press the VOL. +/- button on the remote control to select the 5 step down point from the upper limit on the "OK".
(Example: In case of the "OK" range 30~41, select 36.)

2-3: AGC VOLTAGE

1. Place the set with Aging Test for more than 15 minutes.
2. Receive the VHF HIGH (63dB).
3. Connect the digital voltmeter to pin 5 of CP101.
4. Activate the adjustment mode display of Fig. 1-1 and press the channel button (01) on the remote control to select "RF AGC".
5. Press the VOL. +/- button on the remote control until the digital voltmeter is $2.50 \pm 0.05V$.

2-4: CUT OFF

1. Set condition is AV MODE without signal.
2. Using the remote control, set the brightness and contrast to normal position.
3. Place the set with Aging Test for more than 15 minutes.
4. Activate the adjustment mode display of Fig. 1-1 and press the channel button (00) on the remote control to select "CUT OFF".
5. Adjust the Screen Volume until a dim raster is obtained.

2-5: WHITE BALANCE

NOTE: Adjust after performing CUT OFF adjustment.

1. Place the set with Aging Test for more than 15 minutes.
2. Receive the gray scale pattern from the Pattern Generator.
3. Using the remote control, set the brightness and contrast to normal position.
4. Activate the adjustment mode display of Fig. 1-1 and press the channel button (03) on the remote control to select "R DRIVE".
5. Press the Page UP/DOWN button on the remote control to select the "R DRIVE", "G DRIVE", "M R CUTOFF" or "M G CUTOFF".
6. Adjust the VOL. +/- button on the remote control to whiten the R DRIVE, G DRIVE, M R CUT OFF, and M G CUT OFF at each step tone sections equally.
7. Perform the above adjustments 5 and 6 until the white color is looked like a white.

ELECTRICAL ADJUSTMENTS

2-6: FOCUS

1. Receive a 70dB monoscope pattern.
2. Turn the Focus Volume fully counterclockwise once.
3. Adjust the **Focus Volume** until picture is distinct.

2-7: HORIZONTAL POSITION

1. Receive the monoscope pattern from the Pattern Generator.
2. Using the remote control, set the brightness and contrast to normal position.
3. Activate the adjustment mode display of **Fig. 1-1** and press the channel button (**08**) on the remote control to select "H POSI (50)".
4. Press the VOL. +/- button on the remote control until the SHIFT quantity of the OVER SCAN on right and left becomes minimum.
5. Receive the monoscope pattern of NTSC. (Audio Video Input)
6. Set to the AV mode.
7. Using the remote control, set the brightness and contrast to normal position.
8. Activate the adjustment mode display of **Fig. 1-1** and press the channel button (**39**) on the remote control to select "H POSI (60)".
9. Press the VOL. +/- button on the remote control until the SHIFT quantity of the OVER SCAN on right and left becomes minimum.

2-8: VERTICAL POSITION/VERTICAL LINEARITY

1. Receive the monoscope pattern from the Pattern Generator.
2. Using the remote control, set the brightness and contrast to normal position.
3. Adjust the **VR401** until the horizontal line becomes fit to the notch of the shadow mask.
4. Adjust the **VR420** until the SHIFT quantity of the OVER SCAN on upside and downside becomes minimum.

2-9: VERTICAL SIZE

1. Receive the monoscope pattern from the Pattern Generator.
2. Using the remote control, set the brightness and contrast to normal position.
3. Activate the adjustment mode display of **Fig. 1-1** and press the channel button (**11**) on the remote control to select "V SIZE (50)".
4. Press the VOL. +/- button on the remote control adjust the V.SIZE becomes $8 \pm 2\%$.
5. Receive a broadcast and check if the picture is normal.
6. Receive the monoscope pattern of NTSC. (Audio Video Input)
7. Set to the AV mode.
8. Using the remote control, set the brightness and contrast to normal position.
9. Activate the adjustment mode display of **Fig. 1-1** and press the channel button (**12**) on the remote control to select "V SIZE (60)".
10. Press the VOL. +/- button on the remote control adjust the V.SIZE becomes $10 \pm 2\%$.
11. Receive a broadcast and check if the picture is normal.

2-10: BRIGHT CENT

1. Receive the PAL black pattern*. (RF Input)
2. Using the remote control, set the brightness and contrast to normal position.
3. Place the set with Aging Test for more than 15 minutes.
4. Activate the adjustment mode display of **Fig. 1-1** and press the channel button (**17**) on the remote control to select "BRIGHT CENT".
5. Press the VOL. +/- button on the remote control until the screen begin to shine.
6. Receive the PAL black pattern*. (Audio Video Input)
7. Set to the AV mode. Then perform the above adjustments 2-5.

*The Black Pattern means the whole black raster signal. Select the "RASTER" of the pattern generator, set to the OFF position for each R, G and B.

2-11: CONTRAST CENT

1. Activate the adjustment mode display of **Fig. 1-1** and press the channel button (**22**) on the remote control to select "CONTRAST CENT".
2. Press the VOL. +/- button on the remote control until the contrast step No. becomes "35".
3. Receive a broadcast and check if the picture is normal.
4. Set to the AV mode. Then perform the above adjustment 1-3.

2-12: COLOR CENT

1. Receive the PAL color bar pattern. (RF Input)
2. Using the remote control, set the brightness, contrast and color to normal position.
3. Connect the oscilloscope to **TP801**.
4. Activate the adjustment mode display of **Fig. 1-1** and press the channel button (**25**) on the remote control to select "COLOR CENT".
5. Adjust the VOLTS RANGE VARIABLE knob of the oscilloscope until the range between white 100% and 0% is set to 5 scales on the screen of the oscilloscope.
6. Press the VOL. +/- button on the remote control until the red color level is adjusted to $90 \pm 10\%$ of the white level. (**Refer to Fig. 2-1**)
7. Receive the PAL color bar pattern. (Audio Video Input)
8. Set to the AV mode. Then perform the above adjustments 2-6.

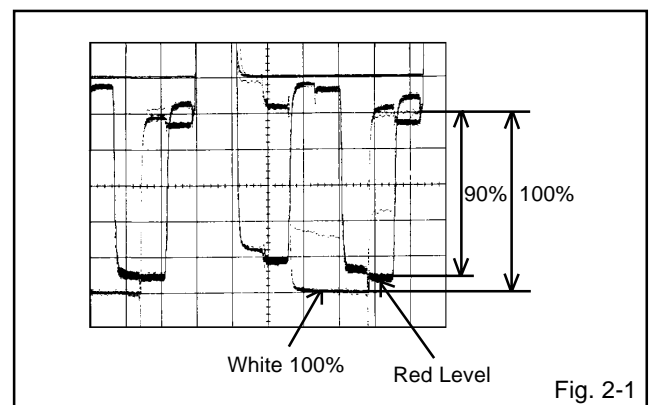

ELECTRICAL ADJUSTMENTS

2-13: TINT

1. Receive the NTSC color bar pattern. (Audio Video Input)
2. Using the remote control, set the brightness and contrast to normal position.
3. Connect the oscilloscope to **TP803**.
4. Activate the adjustment mode display of **Fig. 1-1** and press the channel button **(20)** on the remote control to select "TINT".
5. Press the VOL. +/- button on the remote control until the section "A" becomes a straight line. **(Refer to Fig. 2-2)**

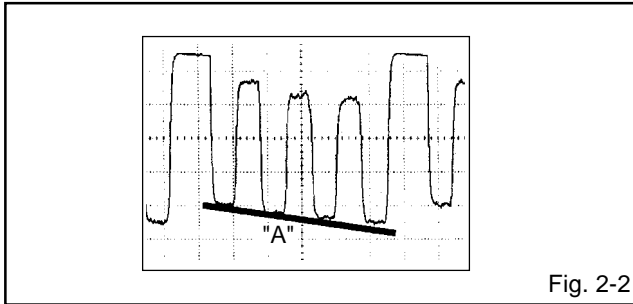

Fig. 2-2

2-14: Confirmation of Fixed Value (Step No.)

Please check if the fixed values of the each adjustment items are set correctly referring below.

NO.	FUNCTION	RF	AV
02	AGC GAIN	00	---
04	R CUTOFF	00	---
06	G CUTOFF	00	---
07	B DRIVE	45	---
09	V POSI (50)	05	---
10	V POSI (60)	00	---
18	BRIGHT MAX	25	25
19	BRIGHT MIN	10	10
20	TINT	30	ADJ.
21	SHARP	02	02
23	CONTRAST MAX	50	50
24	CONTRAST MIN	15	15
26	COLOR MAX	50	50
27	COLOR MIN	10	10
30	M B CUT OFF	127	---
31	CVBS OUT	31	---
32	APR THRESHOLD	00	---
33	BELL FILTER	10	---
34	BANDPASS	00	---
35	H POSI OSD	130	---
36	V POSI OSD	50	---
37	H POSI TEXT	125	---
38	V POSI TEXT	57	---

*To check for the fixed values of the RF (60Hz), indicate the adjustment mode screen while input the 60Hz video signal.

ELECTRICAL ADJUSTMENTS

3. PURITY AND CONVERGENCE ADJUSTMENTS

NOTE

1. Turn the unit on and let it warm up for at least 30 minutes before performing the following adjustments.
2. Place the CRT surface facing east or west to reduce the terrestrial magnetism.
3. Turn ON the unit and demagnetize with a Degauss Coil.

3-1: STATIC CONVERGENCE (ROUGH ADJUSTMENT)

1. Tighten the screw for the magnet. Refer to the adjusted CRT for the position. **(Refer to Fig. 3-1)**
If the deflection yoke and magnet are in one body, untighten the screw for the body.
2. Receive the green raster pattern from the color bar generator.
3. Slide the deflection yoke until it touches the funnel side of the CRT.
4. Adjust center of screen to green, with red and blue on the sides, using the pair of purity magnets.
5. Switch the color bar generator from the green raster pattern to the crosshatch pattern.
6. Combine red and blue of the 3 color crosshatch pattern on the center of the screen by adjusting the pair of 4 pole magnets.
7. Combine red/blue (magenta) and green by adjusting the pair of 6 pole magnets.
8. Adjust the crosshatch pattern to change to white by repeating steps 6 and 7.

3-2: PURITY

NOTE

Adjust after performing adjustments in section 3-1.

1. Receive the green raster pattern from color bar generator.
2. Adjust the pair of purity magnets to center the color on the screen.
Adjust the pair of purity magnets so the color at the ends are equally wide.
3. Move the deflection yoke backward (to neck side) slowly, and stop it at the position when the whole screen is green.
4. Confirm red and blue colors.
5. Adjust the slant of the deflection yoke while watching the screen, then tighten the fixing screw.

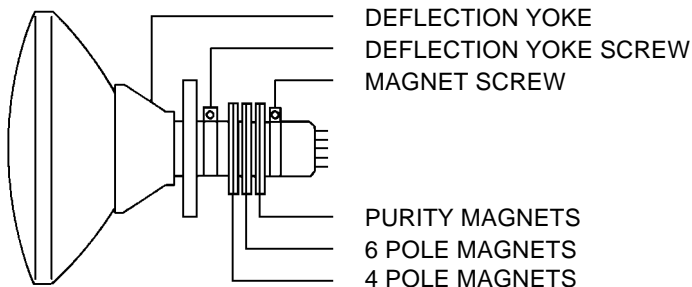

Fig. 3-1

3-3: STATIC CONVERGENCE

NOTE

Adjust after performing adjustments in section 3-2.

1. Receive the crosshatch pattern from the color bar generator.
2. Combine red and blue of the 3 color crosshatch pattern on the center of the screen by adjusting the pair of 4 pole magnets.
3. Combine red/blue (magenta) and green by adjusting the pair of 6 pole magnets.

3-4: DYNAMIC CONVERGENCE

NOTE

Adjust after performing adjustments in section 3-3.

1. Adjust the differences around the screen by moving the deflection yoke upward/downward and right/left. **(Refer to Fig. 3-2-a)**
2. Insert three wedges between the deflection yoke and CRT funnel to fix the deflection yoke. **(Refer to Fig. 3-2-b)**

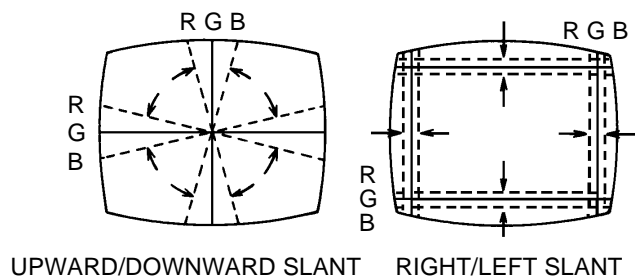

Fig. 3-2-a

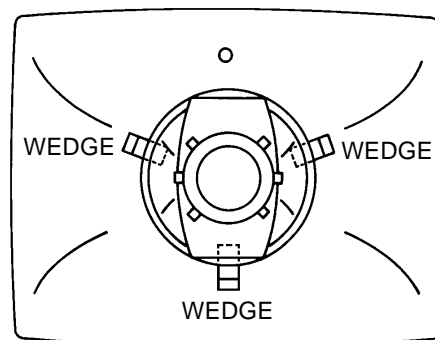
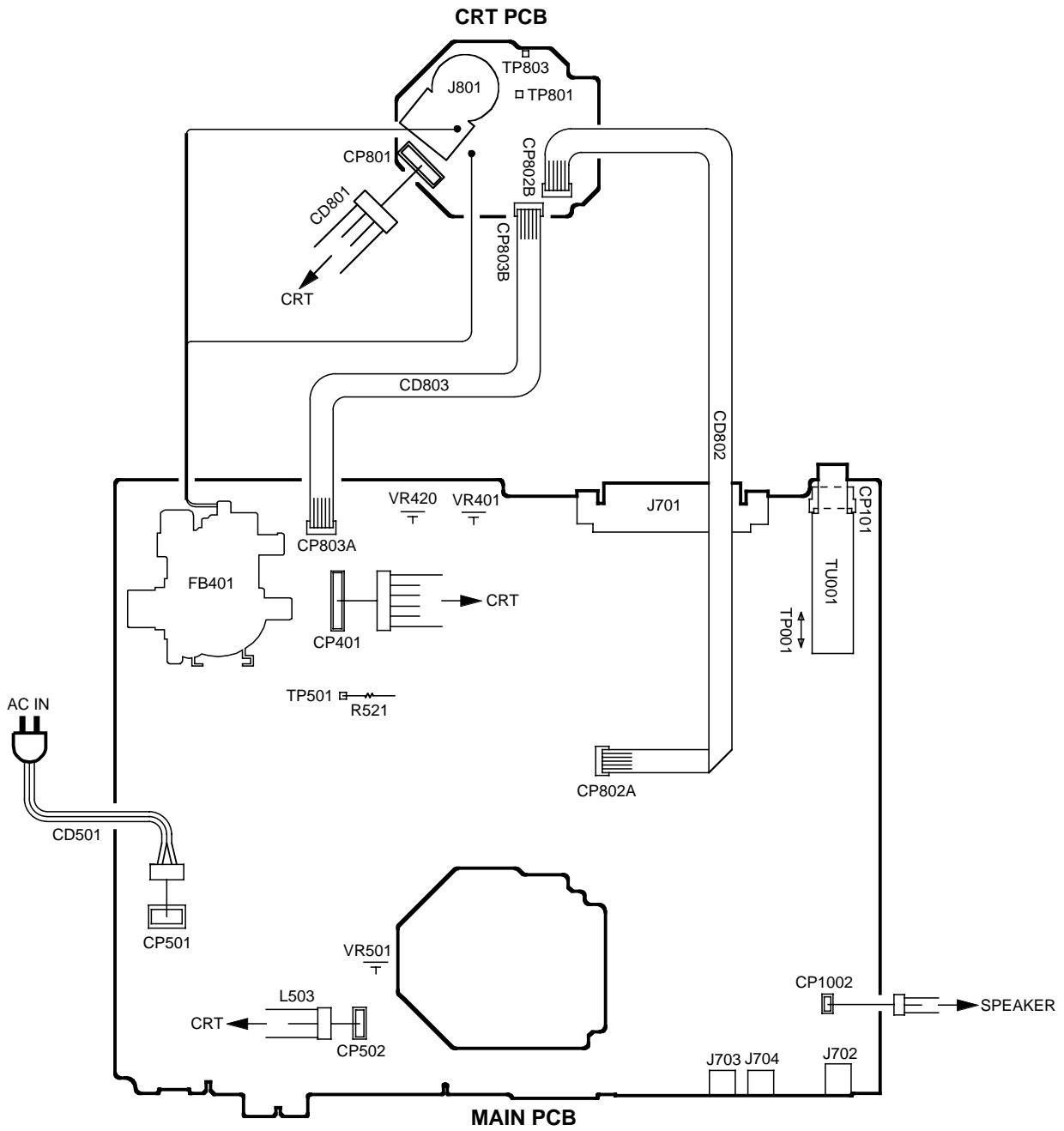

Fig. 3-2-b

ELECTRICAL ADJUSTMENTS

4. ELECTRICAL ADJUSTMENT PARTS LOCATION GUIDE (WIRING CONNECTION)



BLOCK DIAGRAM

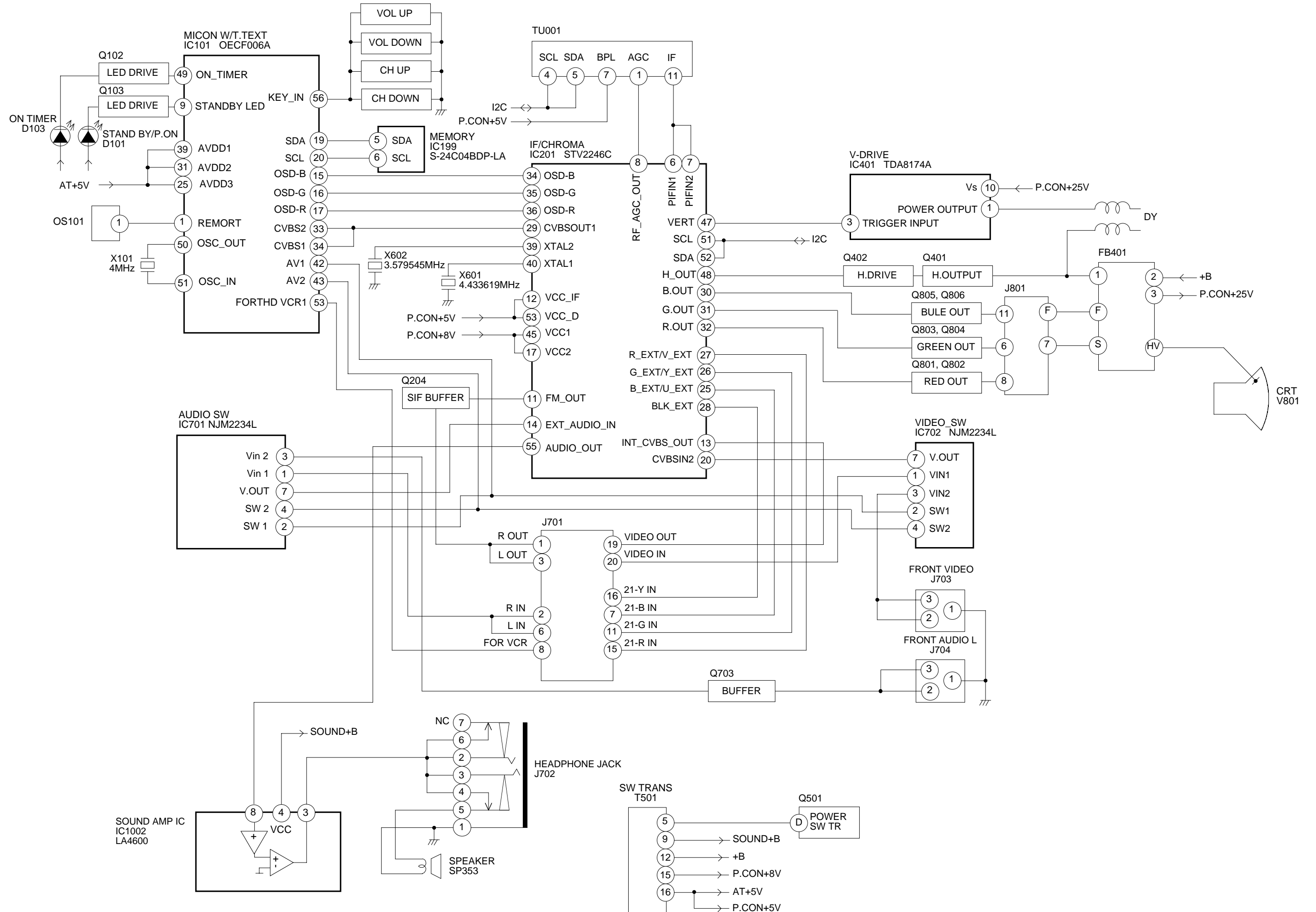

PRINTED CIRCUIT BOARDS
MAIN/CRT (INSERTED PARTS)
SOLDER SIDE

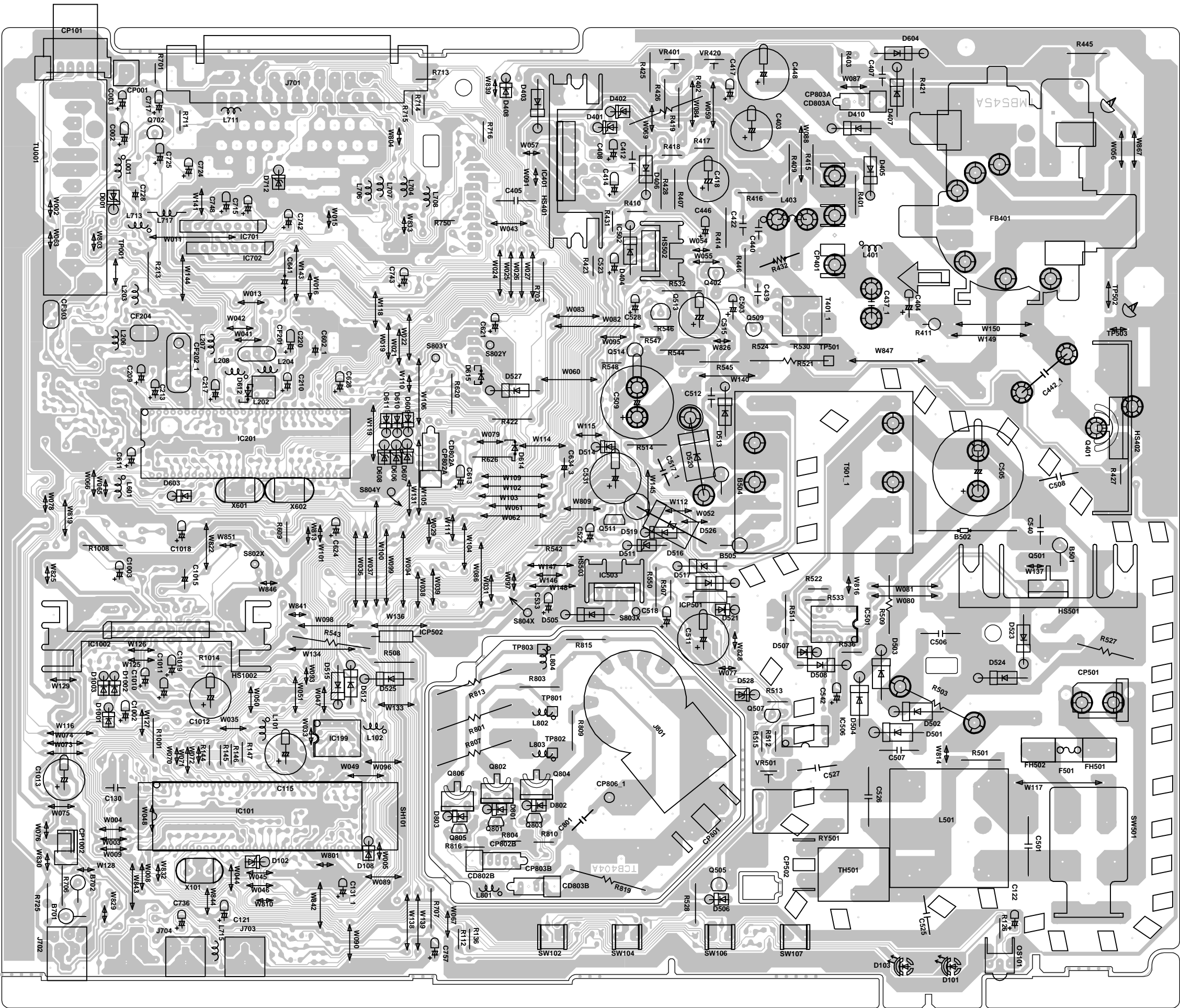

PRINTED CIRCUIT BOARDS
MAIN/CRT (CHIP MOUNTED PARTS)
SOLDER SIDE

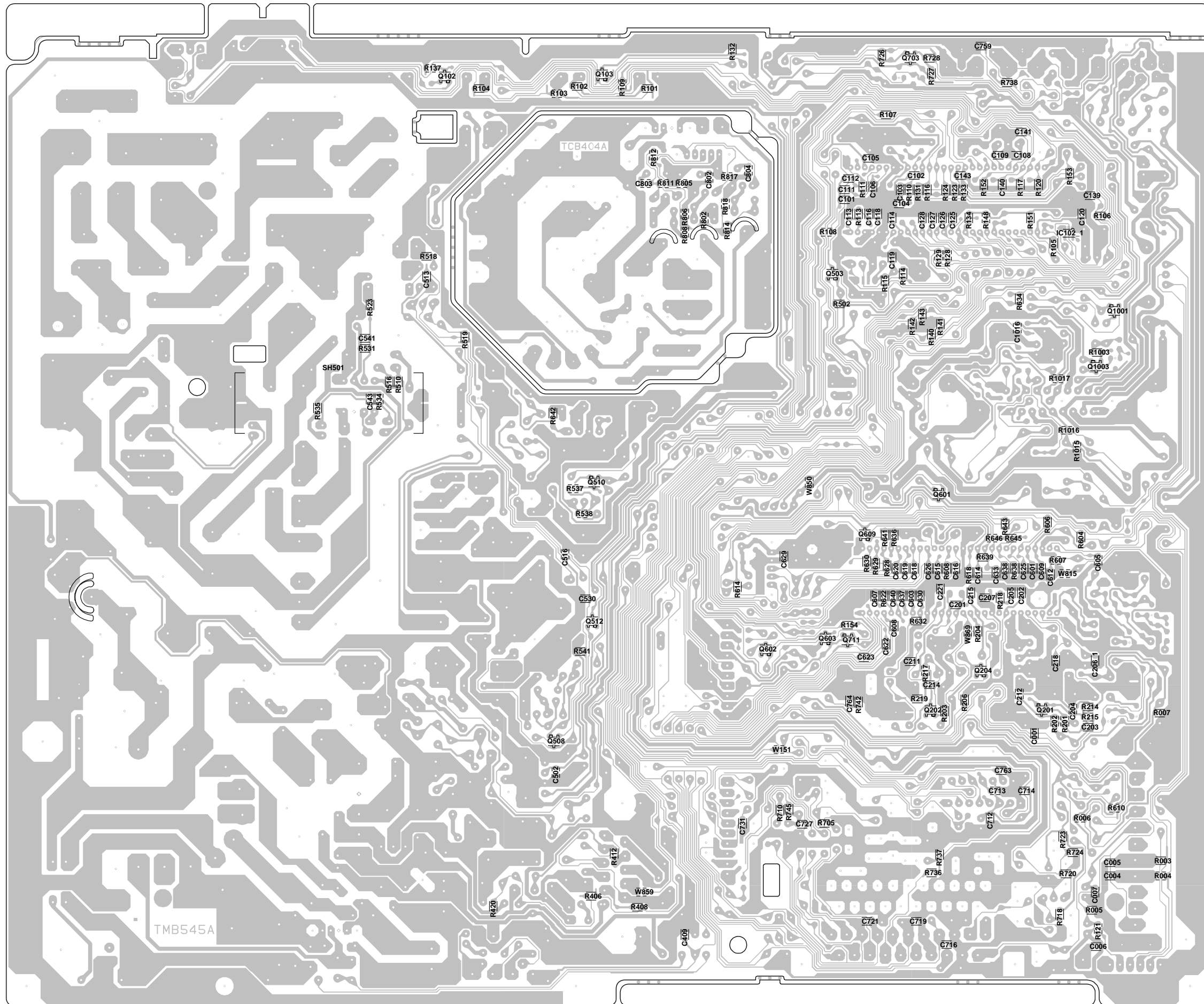

MICON/TUNER SCHEMATIC DIAGRAM (MAIN PCB)

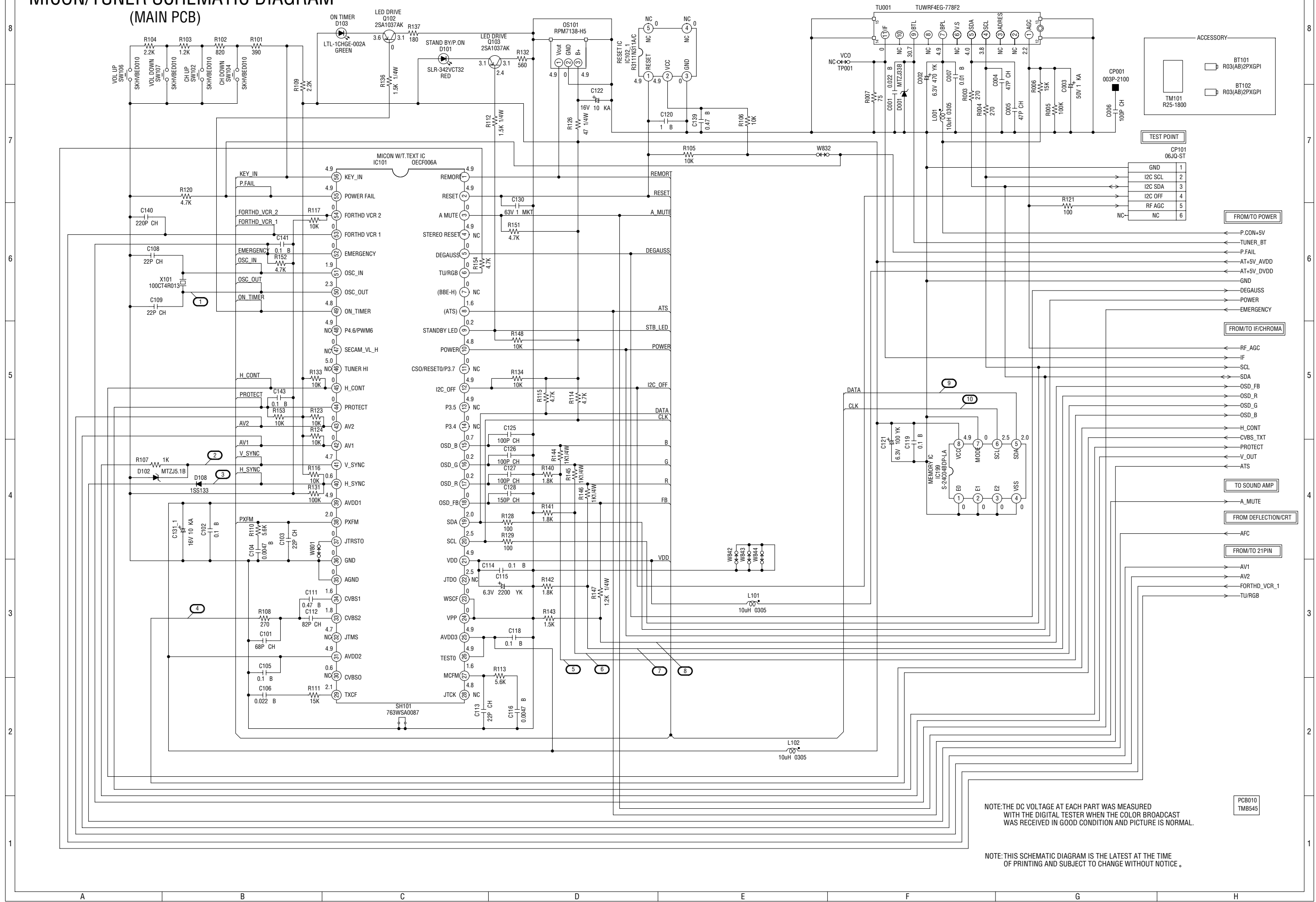

ACCESSORY

- BT101 R03(AB)2PXGPI
- BT102 R03(AB)2PXGPI

TM101 R25-1800

TEST POINT

CP101	06JQ-ST
GND	1
I2C SCL	2
I2C SDA	3
I2C OFF	4
RF AGC	5
NC	6

FROM/TO POWER

FROM/TO IF/CHROMA

TO SOUND AMP

FROM DEFLECTION/CRT

FROM/TO 21PIN

PCB010 TMB545

NOTE: THE DC VOLTAGE AT EACH PART WAS MEASURED WITH THE DIGITAL TESTER WHEN THE COLOR BROADCAST WAS RECEIVED IN GOOD CONDITION AND PICTURE IS NORMAL.

NOTE: THIS SCHEMATIC DIAGRAM IS THE LATEST AT THE TIME OF PRINTING AND SUBJECT TO CHANGE WITHOUT NOTICE.

IF/CHROMA SCHEMATIC DIAGRAM (MAIN PCB)

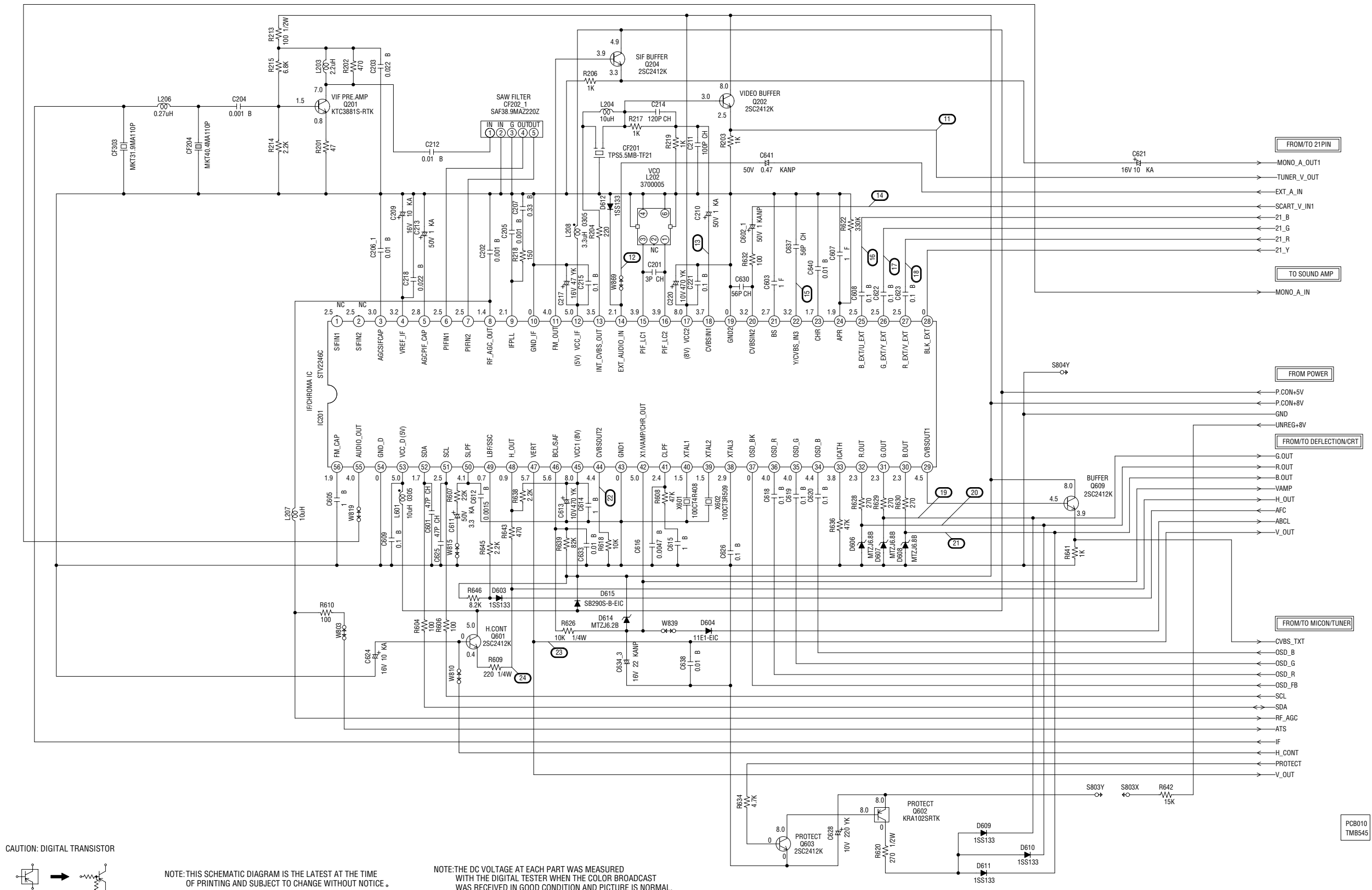

CAUTION: DIGITAL TRANSISTOR

NOTE: THIS SCHEMATIC DIAGRAM IS THE LATEST AT THE TIME OF PRINTING AND SUBJECT TO CHANGE WITHOUT NOTICE.

NOTE: THE DC VOLTAGE AT EACH PART WAS MEASURED WITH THE DIGITAL TESTER WHEN THE COLOR BROADCAST WAS RECEIVED IN GOOD CONDITION AND PICTURE IS NORMAL.

- FROM/TO 21PIN
- MONO_A_OUT1
- TUNER_V_OUT
- EXT_A_IN
- SCART_V_IN1
- 21_B
- 21_G
- 21_R
- 21_Y
- TO SOUND AMP
- MONO_A_IN
- FROM POWER
- P.CON+5V
- P.CON+8V
- GND
- UNREG+8V
- FROM/TO DEFLECTION/CRT
- G.OUT
- R.OUT
- B.OUT
- VAMP
- H.OUT
- AFC
- ABCL
- V_OUT
- FROM/TO MICON/TUNER
- CVBS_TXT
- OSD_B
- OSD_G
- OSD_R
- OSD_FB
- SCL
- SDA
- RF_AGC
- ATS
- IF
- H_CONT
- PROTECT
- V_OUT

PCB010
TMB545

21PIN SCHEMATIC DIAGRAM (MAIN PCB)

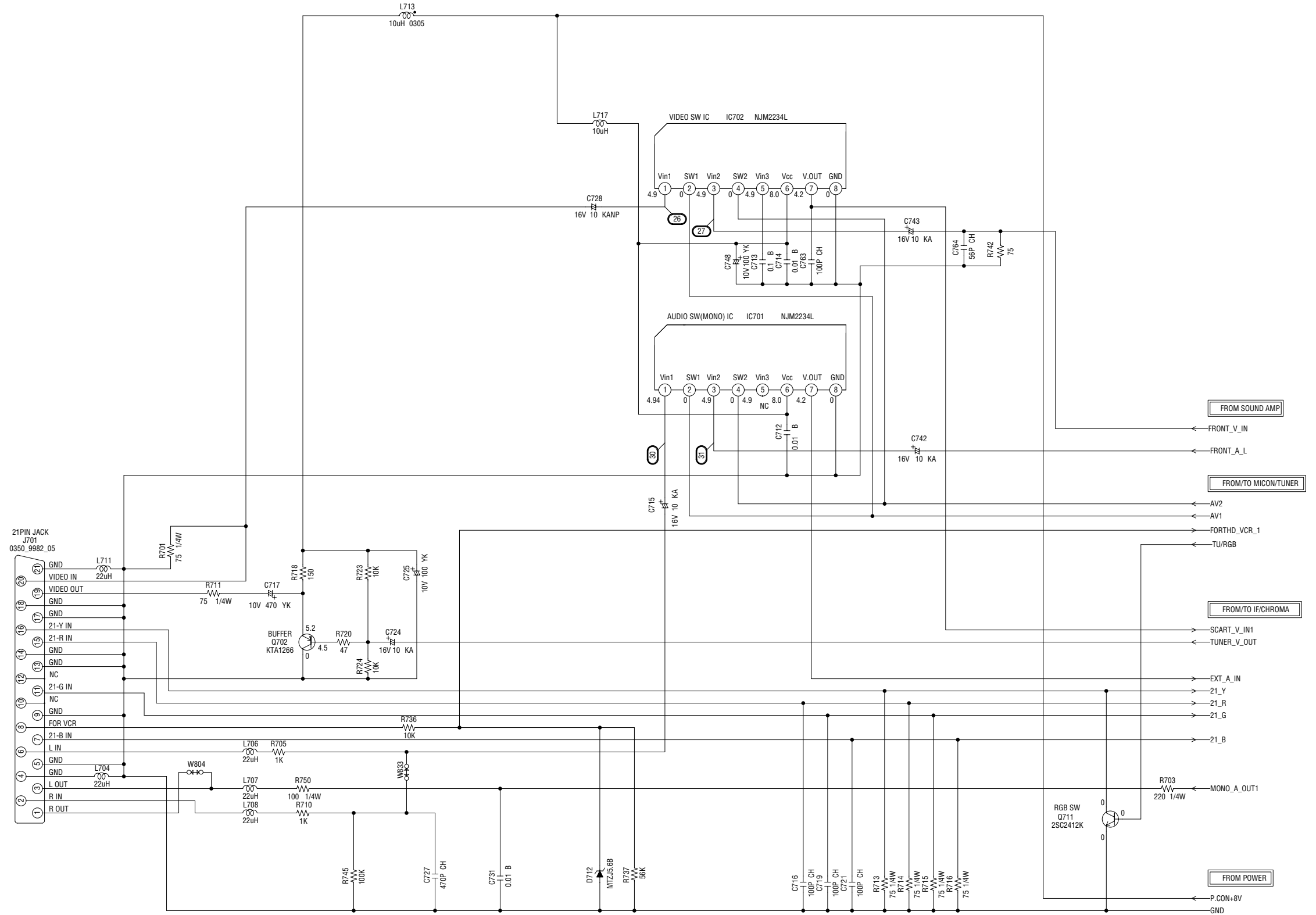



NOTE: THIS SCHEMATIC DIAGRAM IS THE LATEST AT THE TIME OF PRINTING AND SUBJECT TO CHANGE WITHOUT NOTICE.

NOTE: THE DC VOLTAGE AT EACH PART WAS MEASURED WITH THE DIGITAL TESTER WHEN THE COLOR BROADCAST WAS RECEIVED IN GOOD CONDITION AND PICTURE IS NORMAL.

PCB010
TMB545

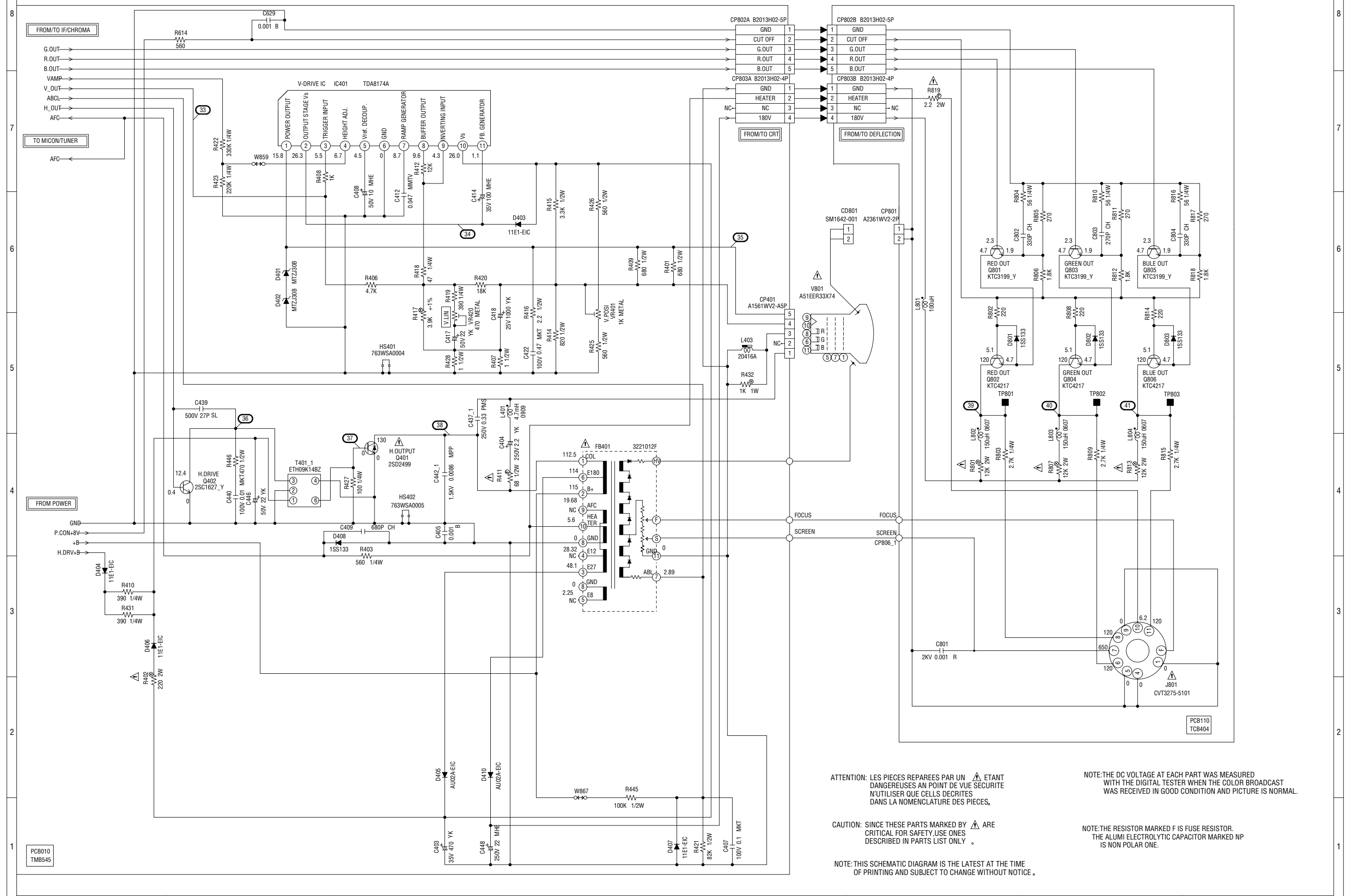
DEFLECTION/CRT SCHEMATIC DIAGRAM (MAIN PCB)



ATTENTION: LES PIÈCES RÉPARÉES PAR UN  ÉTANT DANGEREUSES AU POINT DE VUE SÉCURITÉ N'UTILISER QUE CELLES DÉCRITES DANS LA NOMENCLATURE DES PIÈCES.

NOTE: THE DC VOLTAGE AT EACH PART WAS MEASURED WITH THE DIGITAL TESTER WHEN THE COLOR BROADCAST WAS RECEIVED IN GOOD CONDITION AND PICTURE IS NORMAL.

CAUTION: SINCE THESE PARTS MARKED BY  ARE CRITICAL FOR SAFETY, USE ONES DESCRIBED IN PARTS LIST ONLY.

NOTE: THE RESISTOR MARKED F IS FUSE RESISTOR. THE ALUMI ELECTROLYTIC CAPACITOR MARKED NP IS NON POLAR ONE.

NOTE: THIS SCHEMATIC DIAGRAM IS THE LATEST AT THE TIME OF PRINTING AND SUBJECT TO CHANGE WITHOUT NOTICE.

PCB010
TMB545

PCB110
TCB404

POWER SCHEMATIC DIAGRAM (MAIN PCB)

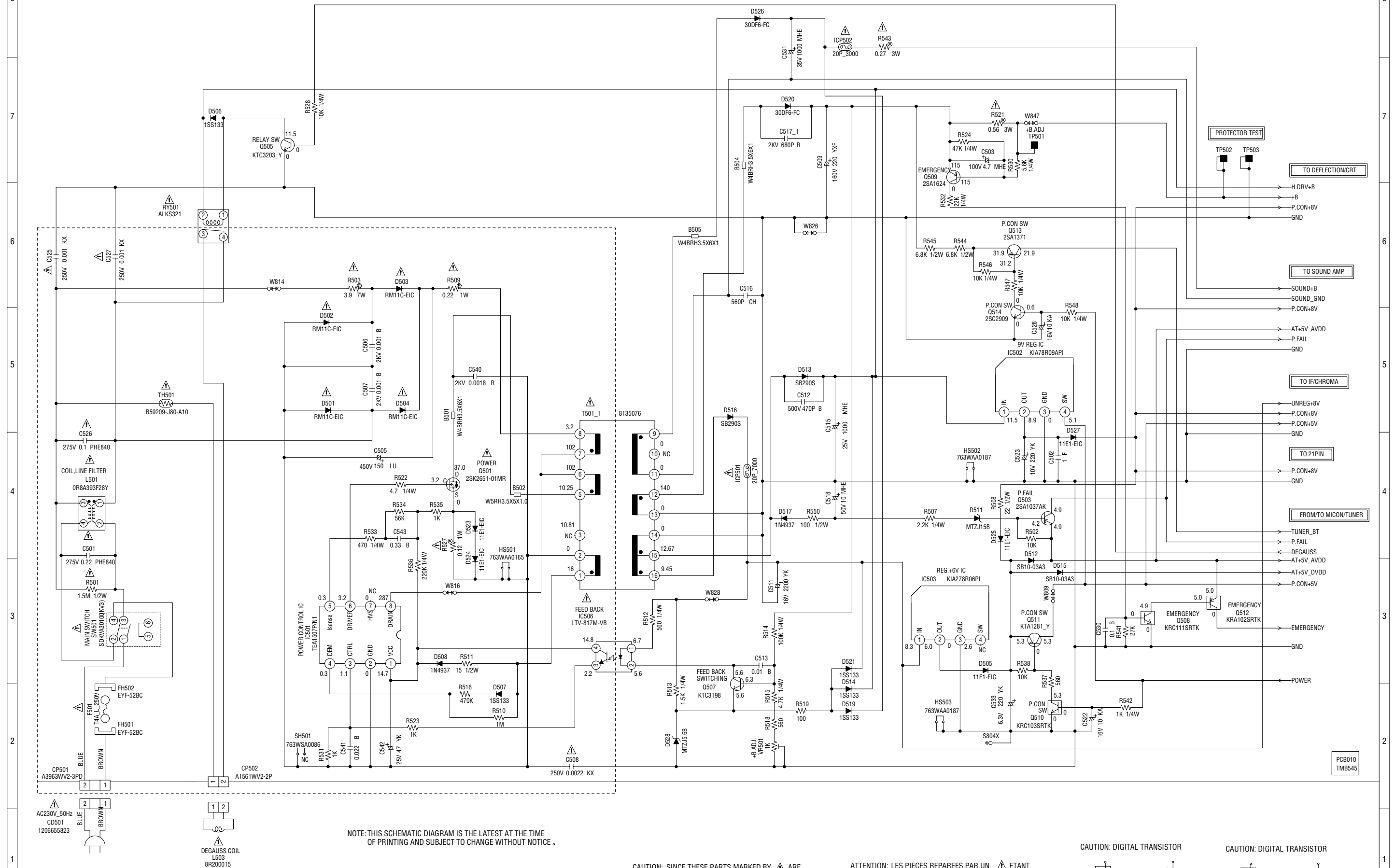

NOTE: THIS SCHEMATIC DIAGRAM IS THE LATEST AT THE TIME OF PRINTING AND SUBJECT TO CHANGE WITHOUT NOTICE.

NOTE: THE DC VOLTAGE AT EACH PART WAS MEASURED WITH THE DIGITAL TESTER WHEN THE COLOR BROADCAST WAS RECEIVED IN GOOD CONDITION AND PICTURE IS NORMAL.

CAUTION: SINCE THESE PARTS MARKED BY ARE CRITICAL FOR SAFETY, USE ONES DESCRIBED IN PARTS LIST ONLY.

ATTENTION: LES PIECES REPARÉES PAR UN ÉTANT DANGEREUSES AN POINT DE VUE SECURITE N'UTILISER QUE CELLS DECRITES DANS LA NOMENCLATURE DES PIECES.

CAUTION: DIGITAL TRANSISTOR

CAUTION: DIGITAL TRANSISTOR



SOUND AMP SCHEMATIC DIAGRAM (MAIN PCB)

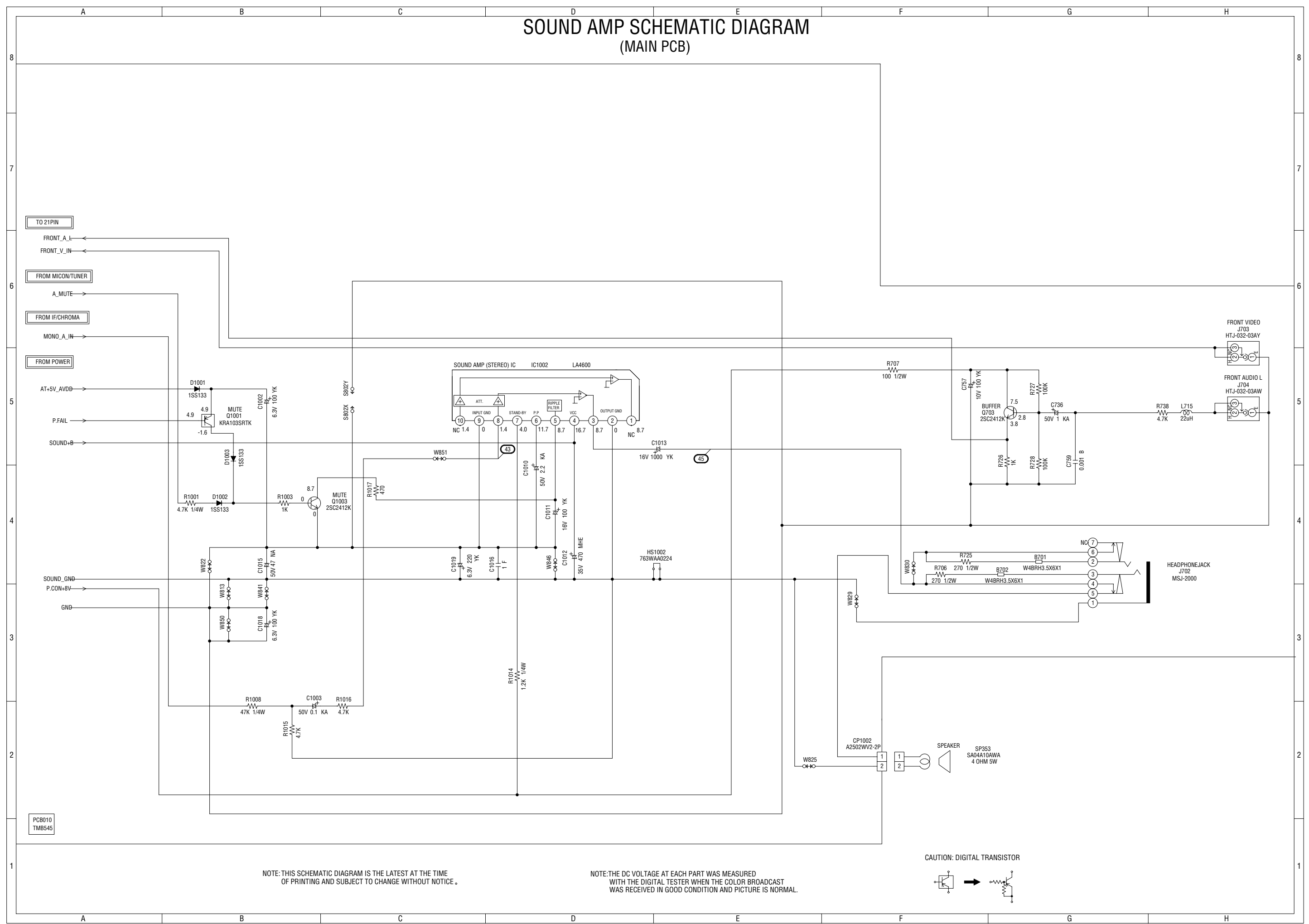

TO 21PIN

FROM MICON/TUNER

FROM IF/CHROMA

FROM POWER

PCB010
TMB545

NOTE: THIS SCHEMATIC DIAGRAM IS THE LATEST AT THE TIME OF PRINTING AND SUBJECT TO CHANGE WITHOUT NOTICE.

NOTE: THE DC VOLTAGE AT EACH PART WAS MEASURED WITH THE DIGITAL TESTER WHEN THE COLOR BROADCAST WAS RECEIVED IN GOOD CONDITION AND PICTURE IS NORMAL.

CAUTION: DIGITAL TRANSISTOR

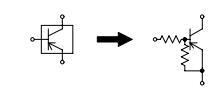

WAVEFORMS

MICON/TUNER

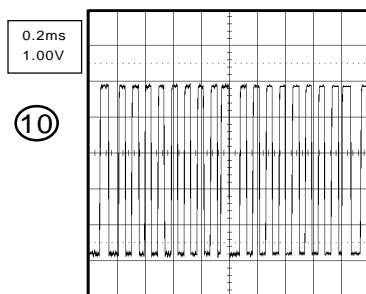
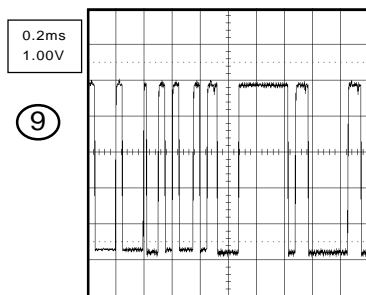
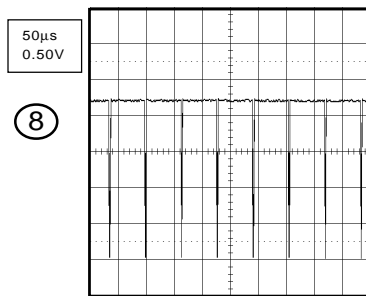
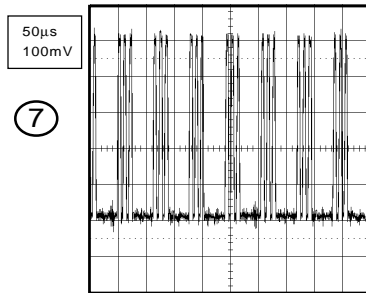
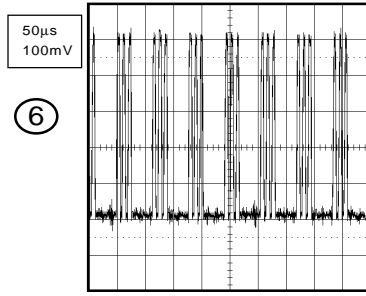
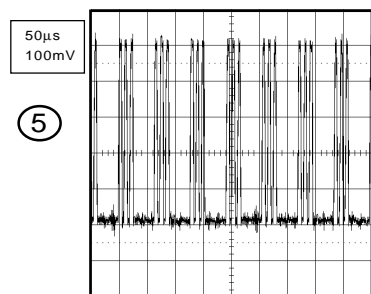
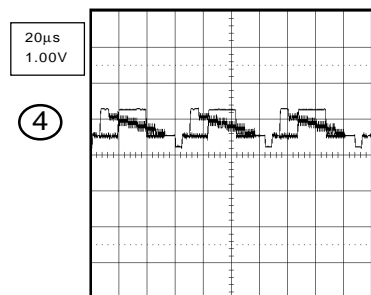
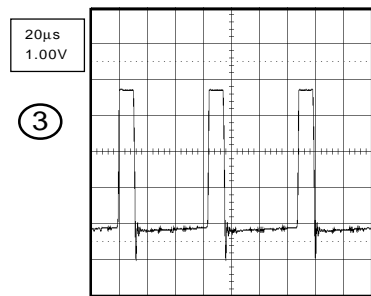
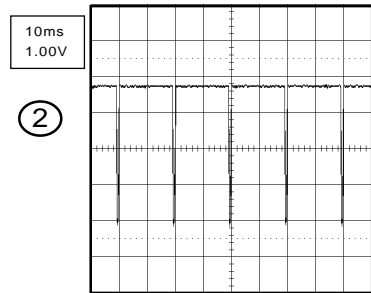
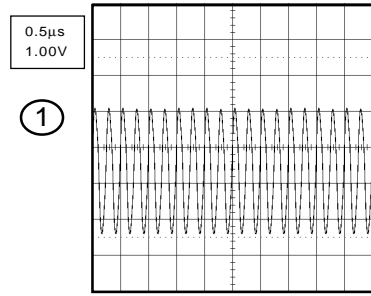

IF/CHROMA

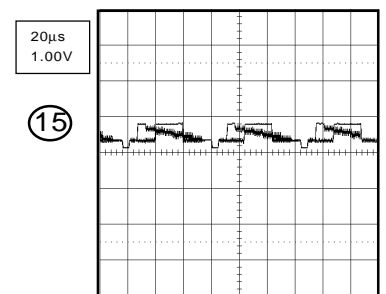
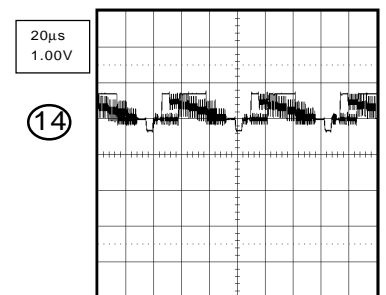
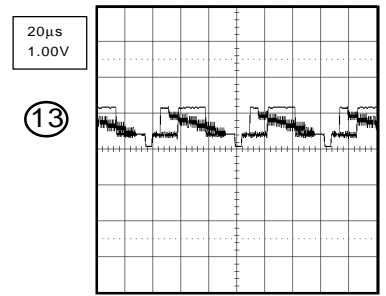
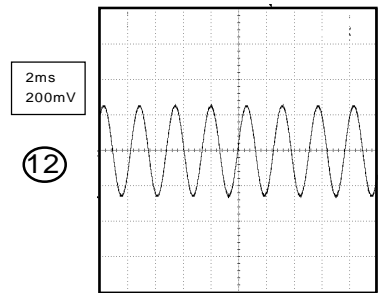
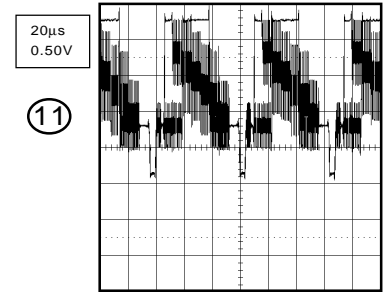

NOTE: The following waveforms were measured at the point of the corresponding balloon number in the schematic diagram.

WAVEFORMS

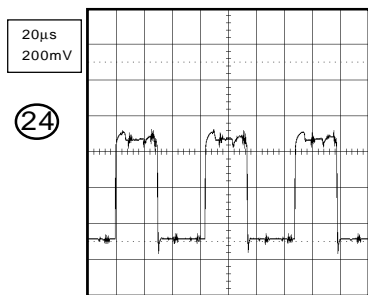
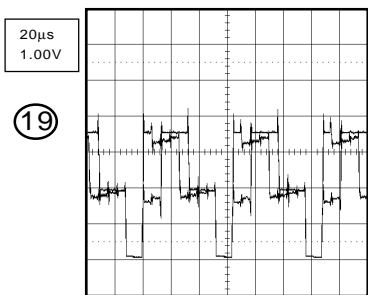
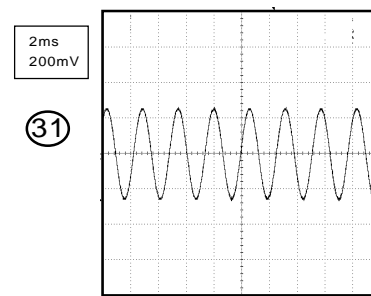
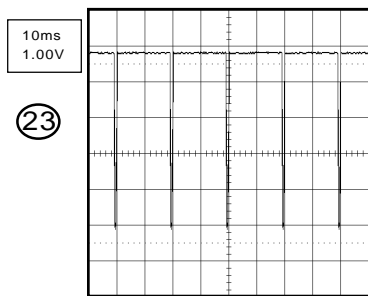
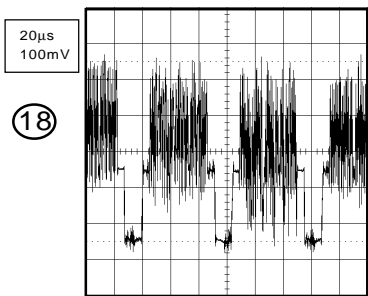
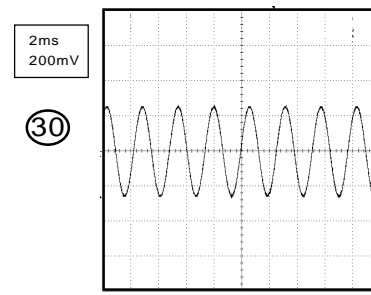
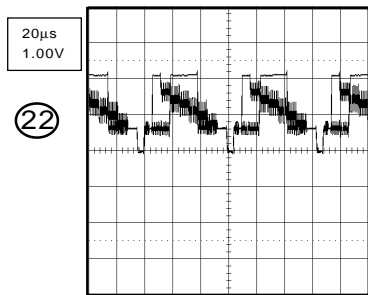
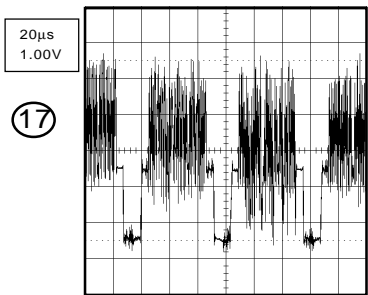
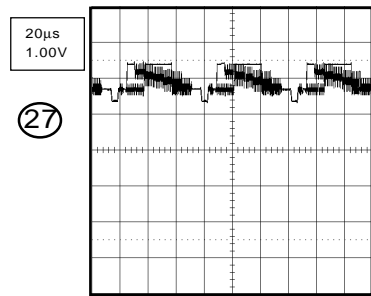
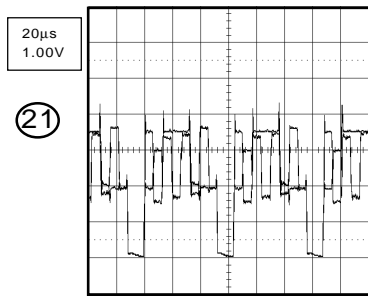
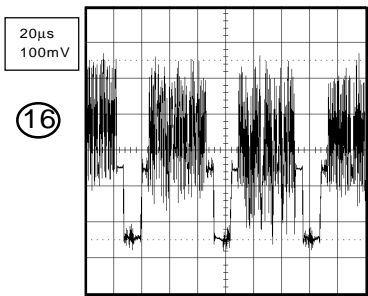

DEFLECTION/CRT

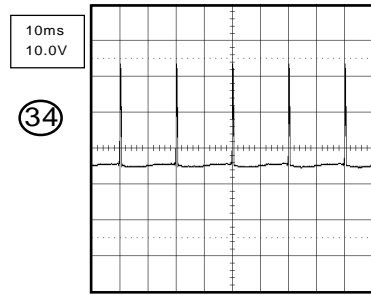
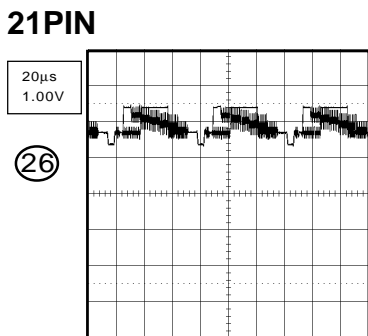
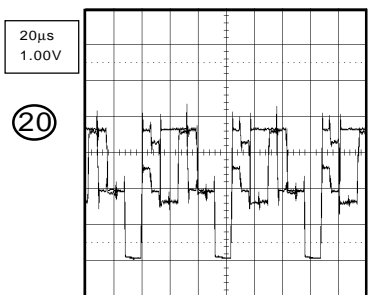
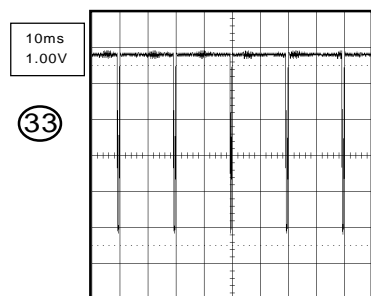

21PIN

NOTE: The following waveforms were measured at the point of the corresponding balloon number in the schematic diagram.

WAVEFORMS

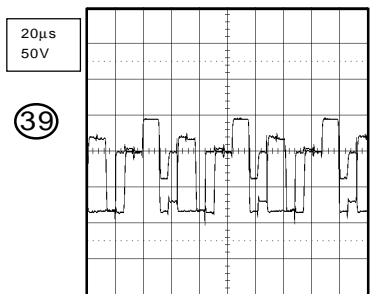
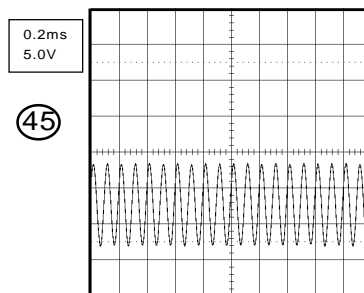
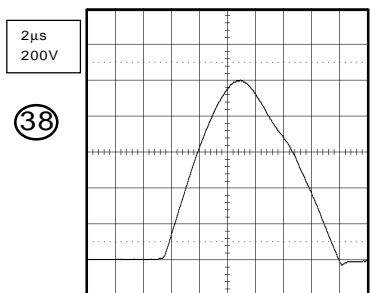
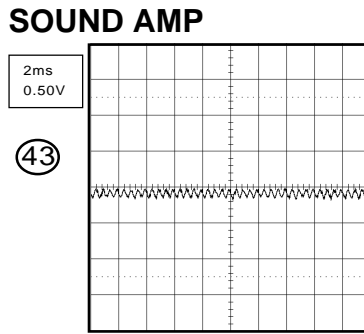
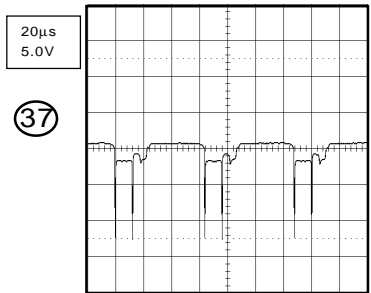
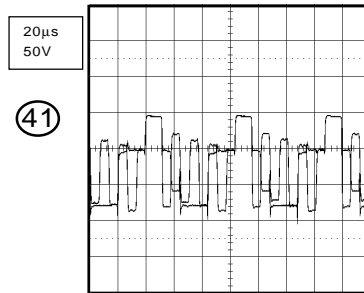
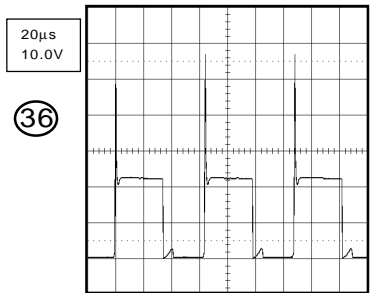
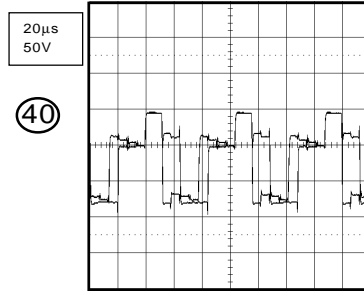
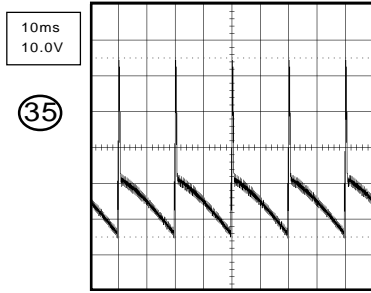

NOTE: The following waveforms were measured at the point of the corresponding balloon number in the schematic diagram.

MECHANICAL EXPLODED VIEW

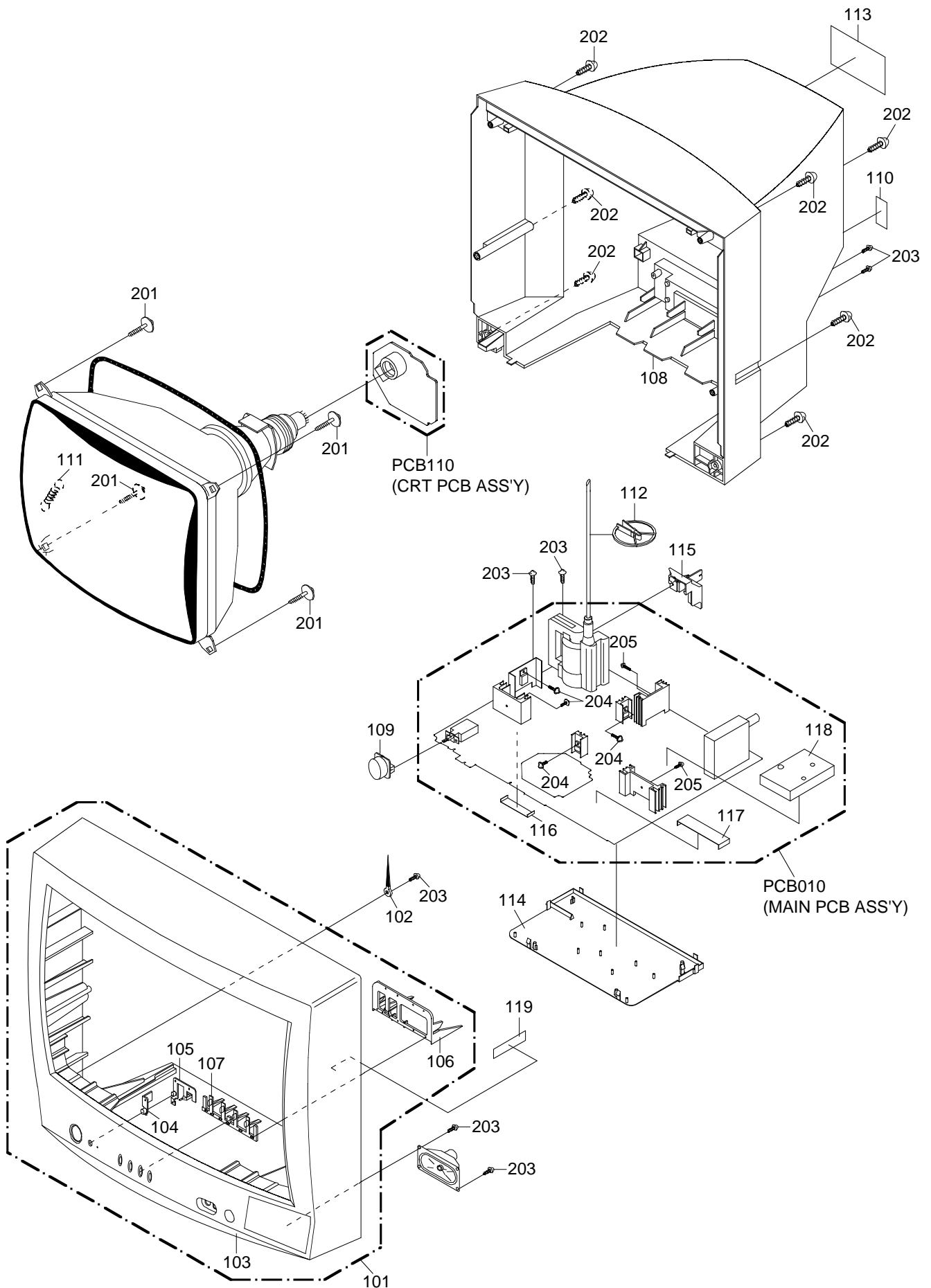

MECHANICAL REPLACEMENT PARTS LIST

REF. NO.	PART NO.	DESCRIPTION
101	A3L906G720	CABINET,FRONT ASSY
102	8995034000	CORD CLIP UL CO.
103	701WPJ1142	CABINET,FRONT
104	711WPA0171	PLATE,FRONT
105	713WPA0214	GUIDE,REMOCON
106	735WPA0667	BUTTON,BASE
107	735WPB0233	BUTTON,FRAME
108	702UPA0253	CABINET,BACK
109	735WPB0234	BUTTON,POWER
110	7230007540	SHEET,JACK
111	741WUA0001	SPRING,EARTH
112	899HV3T001	HOLDER,ANODE WIRE
113	7225490093	SHEET,RATING
114	755WPA0031	COVER,PCB
115	761WPA0258	HOLDER,FBT
116	752WSA0086	SHIELD,IC(30P,40P)
117	752WSA0087	SHIELD,IC
118	752WSA0216	SHIELD,CASE
119	722000A083	SHEET,PTB
201	8121J50B54	SCREW,TAPPING(B0) GW20 5x28
202	8117540A64	SCREW,TAPPING(B0) TRUSS 4x16
203	8110630A04	SCREW,TAP TITE(P) BRAZIER 3x10
204	8109I30A04	SCREW,TAP TITE(B) WH7 3x10
205	8107630804	SCREW,TAP TITE(S) BRAZIER 3x8
---	7230007539	SHEET,BAR CODE
---	791WHA0085	LAMIFILM,BAG
---	792UHA0171	PACKAGE,TOP
---	792UHA0172	PACKAGE,BOTTOM
---	793UCD1185	GIFT BOX
---	A3L906G975	INSTRUCTION BOOK KIT
---	JB5XDA00	POLYBAG,INSTRUCTION(RED CAUTION)
---	J3L90601	INSTRUCTION BOOK(G)
---	J3L90607	QUICK SET-UP SHEET(SW)
---	J3L90610	INSTRUCTION BOOK(H)
---	J3L90611	INSTRUCTION BOOK(I)
---	J3L90651	INSTRUCTION BOOK(T)
---	J3L90661	INSTRUCTION BOOK(GR)
---	J3L90670	QUICK SET-UP SHEET(H)
---	J3L90671	QUICK SET-UP SHEET(I)
---	J3L90673	QUICK SET-UP SHEET(T)
---	J3L90674	QUICK SET-UP SHEET(GR)

ELECTRICAL REPLACEMENT PARTS LIST

REF. NO.	PART NO.	DESCRIPTION	REF. NO.	PART NO.	DESCRIPTION
		RESISTORS			RESISTORS
R003	R801R7271J	RC 270 OHM 1/10W	R422	R002T4334J	RC 330K OHM 1/4W
R004	R801R7271J	RC 270 OHM 1/10W	R423	R002T4224J	RC 220K OHM 1/4W
R005	R801R7104J	RC 100K OHM 1/10W	R425	R002T2561J	RC 560 OHM 1/2W
R006	R801R7153J	RC 15K OHM 1/10W	R426	R002T2561J	RC 560 OHM 1/2W
R007	R801R7750J	RC 75 OHM 1/10W	R427	R002T4101J	RC 100 OHM 1/4W
R101	R801R7391J	RC 390 OHM 1/10W	R428	R002T2010J	RC 1 OHM 1/2W
R102	R801R7821J	RC 820 OHM 1/10W	R431	R002T4391J	RC 390 OHM 1/4W
R103	R801R7122J	RC 1.2K OHM 1/10W	R432	R3K181102J	R,METAL 1K OHM 1W
R104	R801R7222J	RC 2.2K OHM 1/10W	R445	R002T2104J	RC 100K OHM 1/2W
R105	R801R7103J	RC 10K OHM 1/10W	R446	R002T2471J	RC 470 OHM 1/2W
R106	R801R7103J	RC 10K OHM 1/10W	▲ R501	R002T2155J	RC 1.5M OHM 1/2W
R107	R801R7102J	RC 1K OHM 1/10W	R502	R801R7103J	RC 10K OHM 1/10W
R108	R801R7271J	RC 270 OHM 1/10W	▲ R503	R5X2AE3R9J	R,CEMENT 3.9 OHM 7W
R109	R801R7222J	RC 2.2K OHM 1/10W	R507	R002T4222J	RC 2.2K OHM 1/4W
R110	R801R7562J	RC 5.6K OHM 1/10W	R508	R002T2220J	RC 22 OHM 1/2W
R111	R801R7153J	RC 15K OHM 1/10W	▲ R509	R63581R22J	R,FUSE 0.22 OHM 1W
R112	R002T4152J	RC 1.5K OHM 1/4W	R510	R801R7105J	RC 1M OHM 1/10W
R113	R801R7562J	RC 5.6K OHM 1/10W	R511	R002T2150J	RC 15 OHM 1/2W
R114	R801R7472J	RC 4.7K OHM 1/10W	R512	R002T4561J	RC 560 OHM 1/4W
R115	R801R7472J	RC 4.7K OHM 1/10W	R513	R002T4152J	RC 1.5K OHM 1/4W
R116	R801R7103J	RC 10K OHM 1/10W	R514	R002T4104J	RC 100K OHM 1/4W
R117	R801R7103J	RC 10K OHM 1/10W	R515	R002T4472J	RC 4.7K OHM 1/4W
R120	R801R7472J	RC 4.7K OHM 1/10W	R516	R801R7474J	RC 470K OHM 1/10W
R121	R801R7101J	RC 100 OHM 1/10W	R518	R801R7561J	RC 560 OHM 1/10W
R123	R801R7103J	RC 10K OHM 1/10W	R519	R801R7101J	RC 100 OHM 1/10W
R124	R801R7103J	RC 10K OHM 1/10W	▲ R521	R3X28BR56J	R,METAL OXIDE 0.56 OHM 3W
R126	R002T4470J	RC 47 OHM 1/4W	R522	R002T44R7J	RC 4.7 OHM 1/4W
R128	R801R7101J	RC 100 OHM 1/10W	R523	R801R7102J	RC 1K OHM 1/10W
R129	R801R7101J	RC 100 OHM 1/10W	R524	R002T4473J	RC 47K OHM 1/4W
R131	R801R7104J	RC 100K OHM 1/10W	▲ R527	R3X181R12J	R,METAL OXIDE 0.12 OHM 1W
R132	R801R7561J	RC 560 OHM 1/10W	R528	R002T4103J	RC 10K OHM 1/4W
R133	R801R7103J	RC 10K OHM 1/10W	R530	R002T4562J	RC 5.6K OHM 1/4W
R134	R801R7103J	RC 10K OHM 1/10W	R531	R801R7102J	RC 1K OHM 1/10W
R136	R002T4152J	RC 1.5K OHM 1/4W	R532	R002T4223J	RC 22K OHM 1/4W
R137	R801R7181J	RC 180 OHM 1/10W	R533	R002T4471J	RC 470 OHM 1/4W
R140	R801R7182J	RC 1.8K OHM 1/10W	R534	R801R7563J	RC 56K OHM 1/10W
R141	R801R7182J	RC 1.8K OHM 1/10W	R535	R801R7102J	RC 1K OHM 1/10W
R142	R801R7182J	RC 1.8K OHM 1/10W	R536	R002T4224J	RC 220K OHM 1/4W
R143	R801R7152J	RC 1.5K OHM 1/10W	R537	R801R7561J	RC 560 OHM 1/10W
R144	R002T4102J	RC 1K OHM 1/4W	R538	R801R7103J	RC 10K OHM 1/10W
R145	R002T4102J	RC 1K OHM 1/4W	R541	R801R7273J	RC 27K OHM 1/10W
R146	R002T4102J	RC 1K OHM 1/4W	R542	R002T4102J	RC 1K OHM 1/4W
R147	R002T4122J	RC 1.2K OHM 1/4W	▲ R543	R3X28BR27J	R,METAL OXIDE 0.27 OHM 3W
R148	R801R7103J	RC 10K OHM 1/10W	R544	R002T2682J	RC 6.8K OHM 1/2W
R151	R801R7472J	RC 4.7K OHM 1/10W	R545	R002T2682J	RC 6.8K OHM 1/2W
R152	R801R7472J	RC 4.7K OHM 1/10W	R546	R002T4103J	RC 10K OHM 1/4W
R153	R801R7103J	RC 10K OHM 1/10W	R547	R002T4103J	RC 10K OHM 1/4W
R154	R801R7472J	RC 4.7K OHM 1/10W	R548	R002T4103J	RC 10K OHM 1/4W
R201	R801R7470J	RC 47 OHM 1/10W	R550	R002T2101J	RC 100 OHM 1/2W
R202	R801R7471J	RC 470 OHM 1/10W	R604	R801R7101J	RC 100 OHM 1/10W
R203	R801R7102J	RC 1K OHM 1/10W	R606	R801R7101J	RC 100 OHM 1/10W
R204	R801R7221J	RC 220 OHM 1/10W	R607	R801R7223J	RC 22K OHM 1/10W
R206	R801R7102J	RC 1K OHM 1/10W	R608	R801R7473J	RC 47K OHM 1/10W
R213	R002T2101J	RC 100 OHM 1/2W	R609	R002T4221J	RC 220 OHM 1/4W
R214	R801R7222J	RC 2.2K OHM 1/10W	R610	R801R7101J	RC 100 OHM 1/10W
R215	R801R7682J	RC 6.8K OHM 1/10W	R614	R801R7561J	RC 560 OHM 1/10W
R217	R801R7102J	RC 1K OHM 1/10W	R618	R801R7103J	RC 10K OHM 1/10W
R218	R801R7151J	RC 150 OHM 1/10W	R620	R002T2271J	RC 270 OHM 1/2W
R219	R801R7102J	RC 1K OHM 1/10W	R622	R801R7334J	RC 330K OHM 1/10W
▲ R401	R002T2681J	RC 680 OHM 1/2W	R626	R002T4103J	RC 10K OHM 1/4W
▲ R402	R3X18A221J	R,METAL OXIDE 220 OHM 2W	R628	R801R7271J	RC 270 OHM 1/10W
R403	R002T4561J	RC 560 OHM 1/4W	R629	R801R7271J	RC 270 OHM 1/10W
R406	R801R7472J	RC 4.7K OHM 1/10W	R630	R801R7271J	RC 270 OHM 1/10W
R407	R002T2010J	RC 1 OHM 1/2W	R632	R801R7101J	RC 100 OHM 1/10W
R408	R801R7102J	RC 1K OHM 1/10W	R634	R801R7472J	RC 4.7K OHM 1/10W
R409	R002T2681J	RC 680 OHM 1/2W	R636	R801R7473J	RC 47K OHM 1/10W
R410	R002T4391J	RC 390 OHM 1/4W	R638	R801R7222J	RC 2.2K OHM 1/10W
▲ R411	R655U2680J	R,FUSE 68 OHM 1/2W	R639	R801R7823J	RC 82K OHM 1/10W
R412	R801R7123J	RC 12K OHM 1/10W	R641	R801R7102J	RC 1K OHM 1/10W
R414	R002T2821J	RC 820 OHM 1/2W	R642	R801R7153J	RC 15K OHM 1/10W
R415	R002T2332J	RC 3.3K OHM 1/2W	R643	R801R7471J	RC 470 OHM 1/10W
R416	R002T22R2J	RC 2.2 OHM 1/2W	R645	R801R7222J	RC 2.2K OHM 1/10W
R417	R4X5T6392F	R,METAL 3.9K OHM 1/6W	R646	R801R7822J	RC 8.2K OHM 1/10W
R418	R002T4470J	RC 47 OHM 1/4W	R701	R002T4750J	RC 75 OHM 1/4W
R419	R002T4391J	RC 390 OHM 1/4W	R703	R002T4221J	RC 220 OHM 1/4W
R420	R801R7183J	RC 18K OHM 1/10W	R705	R801R7102J	RC 1K OHM 1/10W
R421	R002T2823J	RC 82K OHM 1/2W	R706	R002T2271J	RC 270 OHM 1/2W

ELECTRICAL REPLACEMENT PARTS LIST

REF. NO.	PART NO.	DESCRIPTION	REF. NO.	PART NO.	DESCRIPTION
RESISTORS			CAPACITORS		
R707	R002T2101J	RC 100 OHM 1/2W	C128	CS0RCH4E2J	CC 150 PF 50V CH
R710	R801R7102J	RC 1K OHM 1/10W	C130	P235WE105J	CMP 1 UF 63V MKT
R711	R002T4750J	RC 75 OHM 1/4W	C131	E50HU2100M	CE 10 UF 16V
R713	R002T4750J	RC 75 OHM 1/4W	C139	CS0RB02Q5K	CC 0.47 UF 16V B
R714	R002T4750J	RC 75 OHM 1/4W	C140	CS0RCH4H2J	CC 220 PF 50V CH
R715	R002T4750J	RC 75 OHM 1/4W	C141	CS0RB0315K	CC 0.1 UF 25V B
R716	R002T4750J	RC 75 OHM 1/4W	C143	CS0RB0215K	CC 0.1 UF 16V B
R718	R801R7151J	RC 150 OHM 1/10W	C201	CS0RCH430C	CC 3 PF 50V CH
R720	R801R7470J	RC 47 OHM 1/10W	C202	CS0RB0413K	CC 0.001 UF 50V B
R723	R801R7103J	RC 10K OHM 1/10W	C203	CS0RB04H4K	CC 0.022 UF 50V B
R724	R801R7103J	RC 10K OHM 1/10W	C204	CS0RB0413K	CC 0.001 UF 50V B
R725	R002T2271J	RC 270 OHM 1/2W	C205	CS0RB0413K	CC 0.001 UF 50V B
R726	R801R7102J	RC 1K OHM 1/10W	C206	CS0RB0414K	CC 0.01 UF 50V B
R727	R801R7104J	RC 100K OHM 1/10W	C207	CS0RB02L5K	CC 0.33 UF 16V B
R728	R801R7104J	RC 100K OHM 1/10W	C209	E50HU2100M	CE 10 UF 16V
R736	R801R7103J	RC 10K OHM 1/10W	C210	E50HU5010M	CE 1 UF 50V
R737	R801R7563J	RC 56K OHM 1/10W	C211	CS0RCH412J	CC 100 PF 50V CH
R738	R801R7472J	RC 4.7K OHM 1/10W	C212	CS0RB0414K	CC 0.01 UF 50V B
R742	R801R7750J	RC 75 OHM 1/10W	C213	E50HU5010M	CE 1 UF 50V
R745	R801R7104J	RC 100K OHM 1/10W	C214	CS0RCH4B2J	CC 120 PF 50V CH
R750	R002T4101J	RC 100 OHM 1/4W	C215	CS0RB0315K	CC 0.1 UF 25V B
▲ R801	R3X18A123J	R,METAL OXIDE 12K OHM 2W	C217	E02LU2470M	CE 47 UF 16V
R802	R801R7221J	RC 220 OHM 1/10W	C218	CS0RB04H4K	CC 0.022 UF 50V B
R803	R002T4272J	RC 2.7K OHM 1/4W	C220	E02LU1471M	CE 470 UF 10V
R804	R002T4560J	RC 56 OHM 1/4W	C221	CS0RB0315K	CC 0.1 UF 25V B
R805	R801R7271J	RC 270 OHM 1/10W	C403	E02LT4471M	CE 470 UF 35V
R806	R801R7182J	RC 1.8K OHM 1/10W	C404	E02LTD2R2M	CE 2.2 UF 250V
▲ R807	R3X18A123J	R,METAL OXIDE 12K OHM 2W	C405	CHGTB0413K	CC 0.001 UF 50V B
R808	R801R7221J	RC 220 OHM 1/10W	C407	P235W1104J	CMP 0.1 UF 100V MKT
R809	R002T4272J	RC 2.7K OHM 1/4W	C408	E5EZU5100M	CE 10 UF 50V
R810	R002T4560J	RC 56 OHM 1/4W	C409	CS0RCH4U2J	CC 680 PF 50V CH
R811	R801R7271J	RC 270 OHM 1/10W	C412	P232T0473J	CMPL 0.047 UF 50V MMTV
R812	R801R7182J	RC 1.8K OHM 1/10W	C414	E5EZU4101M	CE 100 UF 35V
▲ R813	R3X18A123J	R,METAL OXIDE 12K OHM 2W	C417	E02LU5220M	CE 22 UF 50V
R814	R801R7221J	RC 220 OHM 1/10W	C418	E02LF3102M	CE 1000 UF 25V
R815	R002T4272J	RC 2.7K OHM 1/4W	C422	P235W1474J	CMP 0.47 UF 100V MKT
R816	R002T4560J	RC 56 OHM 1/4W	C437	P4J7F3334J	CMPP 0.33 UF 250V PMS
R817	R801R7271J	RC 270 OHM 1/10W	C439	C0J7SL5K1J	CC 27 PF 500V SL
R818	R801R7182J	RC 1.8K OHM 1/10W	C440	P235W1103J	CMP 0.01 UF 100V MKT
▲ R819	R6558A2R2J	R,FUSE 2.2 OHM 2W	C442	P4N8FK862H	CMPP 0.0086UF 1.5KV
R1001	R002T4472J	RC 4.7K OHM 1/4W	C446	E02LU5220M	CE 22 UF 50V
R1003	R801R7102J	RC 1K OHM 1/10W	C448	E5EZF0220M	CE 22 UF 250V
R1008	R002T4473J	RC 47K OHM 1/4W	▲ C501	P2472B224M	CMP 0.22UF 275V PHE840
R1014	R002T4122J	RC 1.2K OHM 1/4W	C502	CS0RF0316Z	CC 1 UF 25V F
R1015	R801R7472J	RC 4.7K OHM 1/10W	C503	E5EZT84R7M	CE 4.7 UF 100V
R1016	R801R7472J	RC 4.7K OHM 1/10W	C505	E63J0J151M	CE 150 UF 450V
R1017	R801R7471J	RC 470 OHM 1/10W	C506	C0JBB0713K	CC 0.001 UF 2KV B
CAPACITORS			C507	C0JBB0713K	CC 0.001 UF 2KV B
C001	CS0RB04H4K	CC 0.022 UF 50V B	▲ C508	CD39E0MH3M	CC 0.0022UF 250V
C002	E02LU0471M	CE 470 UF 6.3V	C509	E62NFB221M	CE 220 UF 160V
C003	E50HU5010M	CE 1 UF 50V	C511	E02LF2222M	CE 2200 UF 16V
C004	CS0RCH4Q1J	CC 47 PF 50V CH	C512	C0JTB05Q2K	CC 470 PF 500V B
C005	CS0RCH4Q1J	CC 47 PF 50V CH	C513	CS0RB0414K	CC 0.01 UF 50V B
C006	CS0RCH412J	CC 100 PF 50V CH	C515	E5EZF3102M	CE 1000 UF 25V
C007	CS0RB0414K	CC 0.01 UF 50V B	C516	CS0RCH4S2J	CC 560 PF 50V CH
C101	CS0RCH4U1J	CC 68 PF 50V CH	C517	C03L0R7U2K	CC 680 PF 2KV R
C102	CS0RB0315K	CC 0.1 UF 25V B	C518	E5EZU5100M	CE 10 UF 50V
C103	CS0RCH4H1J	CC 22 PF 50V CH	C522	E50HU2100M	CE 10 UF 16V
C104	CS0RB04Q3K	CC 0.0047UF 50V B	C523	E02LU1221M	CE 220 UF 10V
C105	CS0RB0315K	CC 0.1 UF 25V B	▲ C525	CD39E0M13M	CC 0.001 UF 250V
C106	CS0RB04H4K	CC 0.022 UF 50V B	▲ C526	P2472B104M	CMP 0.1 UF 275V PHE840
C108	CS0RCH4H1J	CC 22 PF 50V CH	▲ C527	CD39E0M13M	CC 0.001 UF 250V
C109	CS0RCH4H1J	CC 22 PF 50V CH	C528	E50HU2100M	CE 10 UF 16V
C111	CS0RB02Q5K	CC 0.47 UF 16V B	C530	CS0RB0315K	CC 0.1 UF 25V B
C112	CS0RCH4W1J	CC 82 PF 50V CH	C531	E5EZF4102M	CE 1000 UF 35V
C113	CS0RCH4H1J	CC 22 PF 50V CH	C533	E02LU0221M	CE 220 UF 6.3V
C114	CS0RB0315K	CC 0.1 UF 25V B	C540	C03L0R7G3K	CC 0.0018UF 2KV R
C115	E02LT0222M	CE 2200 UF 6.3V	C541	CS0RB04H4K	CC 0.022 UF 50V B
C116	CS0RB04Q3K	CC 0.0047UF 50V B	C542	E02LU3470M	CE 47 UF 25V
C118	CS0RB0315K	CC 0.1 UF 25V B	C543	CS0RB02L5K	CC 0.33 UF 16V B
C119	CS0RB0315K	CC 0.1 UF 25V B	C601	CS0RCH4Q1J	CC 47 PF 50V CH
C120	CS0RB0216K	CC 1 UF 16V B	C602	E00NU5010M	CE 1 UF 50 V
C121	E02LU0101M	CE 100 UF 6.3V	C603	CS0RF0316Z	CC 1 UF 25V F
C122	E50HU2100M	CE 10 UF 16V	C605	CS0RB0216K	CC 1 UF 16V B
C125	CS0RCH412J	CC 100 PF 50V CH	C607	CS0RF0316Z	CC 1 UF 25V F
C126	CS0RCH412J	CC 100 PF 50V CH	C608	CS0RB0315K	CC 0.1 UF 25V B
C127	CS0RCH412J	CC 100 PF 50V CH	C609	CS0RB0315K	CC 0.1 UF 25V B

ELECTRICAL REPLACEMENT PARTS LIST

REF. NO.	PART NO.	DESCRIPTION	REF. NO.	PART NO.	DESCRIPTION
CAPACITORS			DIODES		
C611	E50HU53R3M	CE 3.3 UF 50V	△ D504	D2WTRM11C0	DIODE,SILICON RM11C-EIC
C612	CS0RB04E3K	CC 0.0015UF 50V B	D505	D2WT011E10	DIODE,SILICON 11E1-EIC
C613	E02LU1471M	CE 470 UF 10V	D506	D1VT001330	DIODE,SILICON 1SS133T-77
C614	CS0RB0216K	CC 1 UF 16V B	D507	D1VT001330	DIODE,SILICON 1SS133T-77
C615	CS0RB0216K	CC 1 UF 16V B	D508	D2WXN49370	DIODE,SILICON 1N4937
C616	CS0RB04Q3K	CC 0.0047UF 50V B	D511	D97U01501B	DIODE,ZENER MTZJ15B T-77
C618	CS0RB0315K	CC 0.1 UF 25V B	D512	D23U1003A3	DIODE,SCHOTTKY SB10-03A3
C619	CS0RB0315K	CC 0.1 UF 25V B	D513	D2WXB290S0	DIODE,SILICON SB290S
C620	CS0RB0315K	CC 0.1 UF 25V B	D514	D1VT001330	DIODE,SILICON 1SS133T-77
C621	E50HU2100M	CE 10 UF 16V	D515	D23U1003A3	DIODE,SCHOTTKY SB10-03A3
C622	CS0RB0315K	CC 0.1 UF 25V B	D516	D2WXB290S0	DIODE,SILICON SB290S
C623	CS0RB0315K	CC 0.1 UF 25V B	D517	D2WXN49370	DIODE,SILICON 1N4937
C624	E50HU2100M	CE 10 UF 16V	D519	D1VT001330	DIODE,SILICON 1SS133T-77
C625	CS0RCH4Q1J	CC 47 PF 50V CH	D520	D28F30DF60	DIODE,RECTIFIER 30DF6-FC
C626	CS0RB0315K	CC 0.1 UF 25V B	D521	D1VT001330	DIODE,SILICON 1SS133T-77
C628	E02LU1221M	CE 220 UF 10V	D523	D2WT011E10	DIODE,SILICON 11E1-EIC
C629	CS0RB0413K	CC 0.001 UF 50V B	D524	D2WT011E10	DIODE,SILICON 11E1-EIC
C630	CS0RCH4S1J	CC 56 PF 50V CH	D525	D2WT011E10	DIODE,SILICON 11E1-EIC
C633	CS0RB0414K	CC 0.01 UF 50V B	D526	D28F30DF60	DIODE,RECTIFIER 30DF6-FC
C634	E00NU2220M	CE 22 UF 16 V	D527	D2WT011E10	DIODE,SILICON 11E1-EIC
C637	CS0RCH4S1J	CC 56 PF 50V CH	D528	D97U05R61B	DIODE,ZENER MTZJ5.6B T-77
C638	CS0RB0414K	CC 0.01 UF 50V B	D603	D1VT001330	DIODE,SILICON 1SS133T-77
C640	CS0RB0414K	CC 0.01 UF 50V B	D604	D2WT011E10	DIODE,SILICON 11E1-EIC
C641	E02N05R47M	CE 0.47 UF 50V	D606	D97U06R81B	DIODE,ZENER MTZJ6.8B T-77
C712	CS0RB0414K	CC 0.01 UF 50V B	D607	D97U06R81B	DIODE,ZENER MTZJ6.8B T-77
C713	CS0RB0315K	CC 0.1 UF 25V B	D608	D97U06R81B	DIODE,ZENER MTZJ6.8B T-77
C714	CS0RB0414K	CC 0.01 UF 50V B	D609	D1VT001330	DIODE,SILICON 1SS133T-77
C715	E50HU2100M	CE 10 UF 16V	D610	D1VT001330	DIODE,SILICON 1SS133T-77
C716	CS0RCH412J	CC 100 PF 50V CH	D611	D1VT001330	DIODE,SILICON 1SS133T-77
C717	E02LU1471M	CE 470 UF 10V	D612	D1VT001330	DIODE,SILICON 1SS133T-77
C719	CS0RCH412J	CC 100 PF 50V CH	D614	D97U06R21B	DIODE,ZENER MTZJ6.2B T-77
C721	CS0RCH412J	CC 100 PF 50V CH	D615	D2WOB290S0	DIODE,SILICON SB290S-B-EIC
C724	E50HU2100M	CE 10 UF 16V	D712	D97U05R61B	DIODE,ZENER MTZJ5.6B T-77
C725	E02LU1101M	CE 100 UF 10V	D801	D1VT001330	DIODE,SILICON 1SS133T-77
C727	CS0RCH4Q2J	CC 470 PF 50V CH	D802	D1VT001330	DIODE,SILICON 1SS133T-77
C728	E00NU2100M	CE 10 UF 16 V	D803	D1VT001330	DIODE,SILICON 1SS133T-77
C731	CS0RB0414K	CC 0.01 UF 50V B	D1001	D1VT001330	DIODE,SILICON 1SS133T-77
C736	E50HU5010M	CE 1 UF 50V	D1002	D1VT001330	DIODE,SILICON 1SS133T-77
C742	E50HU2100M	CE 10 UF 16V	D1003	D1VT001330	DIODE,SILICON 1SS133T-77
C743	E50HU2100M	CE 10 UF 16V	ICS		
C748	E02LU1101M	CE 100 UF 10V	IC101	I5PD0F006A	IC OECF006A
C757	E02LU1101M	CE 100 UF 10V	IC102	IC7J0311A0	IC R3111N311A/C-TR
C759	CS0RB0413K	CC 0.001 UF 50V B	IC199	A3L906G015	IC S-24C04BDP-LA
C763	CS0RCH412J	CC 100 PF 50V CH	IC201	I0WDE246C0	IC STV2246C
C764	CS0RCH4S1J	CC 56 PF 50V CH	IC401	I0WTD81740	IC TDA8174A
C801	C03L0R713K	CC 0.001 UF 2KV R	IC501	I0WD015070	IC TEA1507P/N1
C802	CS0RCH4L2J	CC 330 PF 50V CH	IC502	I1KA98R09A	IC KIA78R09API or
C803	CS0RCH4K2J	CC 270 PF 50V CH		I0GA909RD0	IC PQ09RD08
C804	CS0RCH4L2J	CC 330 PF 50V CH		I1KA98R060	IC KIA278R06PI
C1002	E02LU0101M	CE 100 UF 6.3V	△ IC503	0002E00610	PHOTO COUPLER LTV-817M-VB
C1003	E50HU50R1M	CE 0.1 UF 50 V	IC501	I0QS02234L	IC NJM2234L
C1010	E50HU52R2M	CE 2.2 UF 50V	IC702	I0QS02234L	IC NJM2234L
C1011	E02LU2101M	CE 100 UF 16V	IC1002	I03SP46000	IC LA4600
C1012	E5EZT4471M	CE 470 UF 35V	TRANSISTORS		
C1013	E02LT2102M	CE 1000 UF 16V	Q102	T6YJ1037K0	TRANSISTOR,SILICON 2SA1037AKT146R,S
C1015	E62KT5470M	CE 47 UF 50V	Q103	T6YJ1037K0	TRANSISTOR,SILICON 2SA1037AKT146R,S
C1016	CS0RF0316Z	CC 1 UF 25V F	Q201	T8AA03881S	TRANSISTOR,SILICON KTC3881S-RTK
C1018	E02LU0101M	CE 100 UF 6.3V	Q202	T8YJ2412K0	TRANSISTOR,SILICON 2SC2412KT146 R,S
C1019	E02LU0221M	CE 220 UF 6.3V	Q204	T8YJ2412K0	TRANSISTOR,SILICON 2SC2412KT146 R,S
DIODES			△ Q401	TDFU024990	TRANSISTOR,SILICON 2SD2499
D001	D97U03301B	DIODE,ZENER MTZJ33B T-77	Q402	TC5T01627Y	TRANSISTOR,SILICON 2SC1627_Y(TPE2)
D101	0021721150	LED SLR-342VCT32	△ Q501	T41F026510	TRANSISTOR,FIELD EFF ECT 2SK2651-01MR
D102	D97U05R11B	DIODE,ZENER MTZJ5.1B T-77	Q503	T6YJ1037K0	TRANSISTOR,SILICON 2SA1037AKT146R,S
D103	0021E5Q210	LED LTL-1CHGE-002A	Q505	TCAT032034	TRANSISTOR,SILICON KTC3203_Y-AT
D108	D1VT001330	DIODE,SILICON 1SS133T-77	Q507	TCATC31980	TRANSISTOR,SILICON KTC3198-AT(Y,GR)
D401	D97U03001B	DIODE,ZENER MTZJ30B T-77	Q508	TNAAJ05003	COMPOUND TRANSISTOR KRC111SRTK
D402	D97U03001B	DIODE,ZENER MTZJ30B T-77	Q509	TA3T016240	TRANSISTOR,SILICON 2SA1624-AA
D403	D2WT011E10	DIODE,SILICON 11E1-EIC	Q510	TNAAC05002	COMPOUND TRANSISTOR KRC103SRTK
D404	D2WT011E10	DIODE,SILICON 11E1-EIC	Q511	TAAT01281Y	TRANSISTOR,SILICON KTA1281_Y
D405	D2WTAU02A0	DIODE,SILICON AU02A-EIC	Q512	TPAAB05001	COMPOUND TRANSISTOR KRA102SRTK
D406	D2WT011E10	DIODE,SILICON 11E1-EIC	Q513	TA3T1371A0	TRANSISTOR,SILICON 2SA1371(D,E)-AE
D407	D2WT011E10	DIODE,SILICON 11E1-EIC	Q514	TC3T029090	TRANSISTOR,SILICON 2SC2909(S,T)-AA
D408	D1VT001330	DIODE,SILICON 1SS133T-77	Q601	T8YJ2412K0	TRANSISTOR,SILICON 2SC2412KT146 R,S
D410	D2WTAU02A0	DIODE,SILICON AU02A-EIC	Q602	TPAAB05001	COMPOUND TRANSISTOR KRA102SRTK
△ D501	D2WTRM11C0	DIODE,SILICON RM11C-EIC	Q603	T8YJ2412K0	TRANSISTOR,SILICON 2SC2412KT146 R,S
△ D502	D2WTRM11C0	DIODE,SILICON RM11C-EIC	Q609	T8YJ2412K0	TRANSISTOR,SILICON 2SC2412KT146 R,S
△ D503	D2WTRM11C0	DIODE,SILICON RM11C-EIC	Q702	TAATA12660	TRANSISTOR,SILICON KTA1266-AT(Y,GR)

ELECTRICAL REPLACEMENT PARTS LIST

REF. NO.	PART NO.	DESCRIPTION	REF. NO.	PART NO.	DESCRIPTION
TRANSISTORS			MISCELLANEOUS		
Q703	T8YJ2412K0	TRANSISTOR,SILICON 2SC2412KT146 R,S	CP101	069X160379	CONNECTOR PCB SIDE 06JQ-ST
Q711	T8YJ2412K0	TRANSISTOR,SILICON 2SC2412KT146 R,S	CP401	069S450089	CONNECTOR PCB SIDE A1561WV2-A5P
Q801	TCATC3199Y	TRANSISTOR,SILICON KTC3199_Y-AT	CP501	069S320419	CONNECTOR PCB SIDE A3963WV2-3PD
Q802	TCA0042170	TRANSISTOR,SILICON KTC4217(O,Y)	CP502	069S420110	CONNECTOR PCB SIDE A1561WV2-2P
Q803	TCATC3199Y	TRANSISTOR,SILICON KTC3199_Y-AT	CP801	069S320010	CONNECTOR PCB SIDE A2361WV2-2P
Q804	TCA0042170	TRANSISTOR,SILICON KTC4217(O,Y)	CP1002	069S120419	CONNECTOR PCB SIDE A2502WV2-2P
Q805	TCATC3199Y	TRANSISTOR,SILICON KTC3199_Y-AT	CP802A	067U005049	WIRE HOLDER B2013H02-5P
Q806	TCA0042170	TRANSISTOR,SILICON KTC4217(O,Y)	CP802B	067U005049	WIRE HOLDER B2013H02-5P
Q1001	TPAAC05002	COMPOUND TRANSISTOR KRA103SRTK	CP803A	067U004029	WIRE HOLDER B2013H02-4P
Q1003	T8YJ2412K0	TRANSISTOR,SILICON 2SC2412KT146 R,S	CP803B	067U004029	WIRE HOLDER B2013H02-4P
COILS & TRANSFORMERS			EL001	124116281A	EYE LET XRY16X28BD
L001	02167F100J	COIL 10 UH	EL002	124120301A	EYE LET XRY20X30BD
L101	02167F100J	COIL 10 UH	△ F501	080NT04003	FUSE 50T040HCC
L102	02167F100J	COIL 10 UH	△ FB401	043221012F	TRANSFORMER,FLYBACK 3221012F
L202	033700005R	COIL,VIDEO IFT 3700005	FH501	06710T0006	HOLDER,FUSE EYF-52BC
L203	021LA62R2K	COIL 2.2 UH	FH502	06710T0006	HOLDER,FUSE EYF-52BC
L204	021LA6100J	COIL 10 UH	△ ICP501	0845T07003	IC PROTECTOR 20P_7000
L206	021LA6R27M	COIL 0.27 UH	△ ICP502	0845T03003	IC PROTECTOR 20P_3000
L207	021LA6100J	COIL 10 UH	OS101	0773071001	REMOTE RECEIVER RPM7138-H5
L208	02167F3R3J	COIL 3.3 UH	△ RY501	0560V20115	RELAY ALKS321
L401	021679472K	COIL 4.7 MH	SP353	070C535004	SPEAKER SA04A10AWA
L403	022800033A	COIL,LINEARITY 20416A	△ TH501	D8E080A100	DEGAUSS ELEMENT B59209-J80-A10
△ L501	029T000091	COIL,LINE FILTER 0R8A393F28Y	TM101	076R0EY020	TRANSMITTER R25-1800
△ L503	028R200015	COIL,DEGAUSS 8R200015	TU001	0145517006	TUNER,VHF-UHF TUWRF4EG-778F2
L601	02167F100J	COIL 10 UH	△ V801	098A210440	CRT W/DY A51EER33X74
L704	021LA6220J	COIL 22 UH	X101	100CT4R013	CRYSTAL HC-49/U-S
L706	021LA6220J	COIL 22 UH	X601	100CT4R408	CRYSTAL HC-49/U
L707	021LA6220J	COIL 22 UH	X602	100CT3R509	CRYSTAL HC-49/U
L708	021LA6220J	COIL 22 UH			
L711	021LA6220J	COIL 22 UH			
L713	02167F100J	COIL 10 UH			
L715	021LA6220J	COIL 22 UH			
L717	021LA6100J	COIL 10 UH			
L801	021673101J	COIL 100 UH			
L802	02167D151K	COIL 150 UH			
L803	02167D151K	COIL 150 UH			
L804	02167D151K	COIL 150 UH			
T401	045009003J	TRANS,HORIZONTAL DRIVE ETH09K14BZ			
△ T501	0481350764	TRANSFORMER,SWITCHING 8135076			
JACKS			RESISTOR		
J701	063G100042	SOCKET,21PIN 0350_9982_05	RC.....		CARBON RESISTOR
J702	060J131015	HEADPHONE JACK MSJ-2000			
J703	060G401047	RCA JACK HTJ-032-03AY			
J704	060G401046	RCA JACK HTJ-032-03AW			
△ J801	066C130017	SOCKET,CATHODE RAY TUBE CVT3275-5101			
SWITCHES			CAPACITORS		
SW102	0504201T31	SWITCH,TACT SKHVBED010	CC.....		CERAMIC CAPACITOR
SW104	0504201T31	SWITCH,TACT SKHVBED010	CE.....		ALUMI ELECTROLYTIC CAPACITOR
SW106	0504201T31	SWITCH,TACT SKHVBED010	CP.....		POLYESTER CAPACITOR
SW107	0504201T31	SWITCH,TACT SKHVBED010	CPP.....		POLYPROPYLENE CAPACITOR
△ SW501	0530205016	SWITCH SDKVA30100	CPL.....		PLASTIC CAPACITOR
VARIABLE RESISTORS			CMP.....		METAL POLYESTER CAPACITOR
VR401	V1K6213BT8	VOLUME,SEMI FIXED NVG6THTB102	CMPL.....		METAL PLASTIC CAPACITOR
VR420	V1K62Q2BT8	VOLUME,SEMI FIXED NVG6THTB471	CMPP.....		METAL POLYPROPYLENE CAPACITOR
VR501	V116313BTC	VOLUME,SEMI FIXED EVNCRYAA03B13			
P.C.BOARD ASSEMBLIES					
PCB010	A3L906G010K	PCB ASSY TMB545A			
PCB110	A3L906G110K	PCB ASSY TCB404A			
MISCELLANEOUS					
B501	024HT03564	CORE,BEADS W4BRH3.5X6X1			
B502	024HT03553	CORE,BEADS W5RH3.5X5X1.0			
B504	024HT03564	CORE,BEADS W4BRH3.5X6X1			
B505	024HT03564	CORE,BEADS W4BRH3.5X6X1			
B701	024HT03564	CORE,BEADS W4BRH3.5X6X1			
B702	024HT03564	CORE,BEADS W4BRH3.5X6X1			
BT101	1412004013	BATTERY,MANGAN R03(AB)2PXGPI			
BT102	1412004013	BATTERY,MANGAN R03(AB)2PXGPI			
△ CD501	1206655823	CORD AC BUSH 1206655823			
CD801	1278210014	BRAIDED WIRE SM1642-001			
CD802	WCL6840038	FLAT CABLE AWM2468 AWG26 5C GRAY 400MM			
CD803	WBL6034038	FLAT CABLE AWM2468 AWG26 4C BLACK 340MM			
CF201	1012T5R503	FILTER,CERAMIC TRAP TPS5.5MB-TF21			
CF202	1022T38R9A	FILTER,SAW SAF38.9MAZ220Z			
CF204	1012T04001	FILTER,CERAMIC TRAP MKT40.4MA110P-TF			
CF303	1012T03101	FILTER,CERAMIC TRAP MKT31.9MA110P-TF			
CP001	069D01001A	CONNECTOR PCB SIDE 003P-2100 or			
	069W01001A	CONNECTOR PCB SIDE 003P-2100			

TOSHIBA Information Systems (UK) Ltd

Consumer Products Division, European Service Centre, Admiralty Way, Camberley, Surrey. GU15 3DT